

## POLICY AND SERVICES

**PRICING:** All prices are unassembled, F.O.B. Tennsco Corp's Facility in Dickson, Tennessee. All orders are subject to final acceptance at the Home Office, Dickson, Tennessee. Prices are subject to change without notice. Tennsco has the right to make product design changes at any time. Tennsco's prices do not include sales, use, excise or similar taxes. Consequently, in addition to the prices specified herein, the amount of any present or future sales, use, excise or similar tax applicable to the manufacture, sale, purchase or use of the goods sold hereunder shall be paid by Buyer. In lieu thereof, Buyer shall provide Seller with a tax exemption certificate acceptable to the applicable taxing authorities.

**TERMS OF PAYMENT:** Terms are Net 30 Days from date of shipment. A service charge of 1<sup>1</sup>/<sub>2</sub>% per month will be charged for overdue invoices.

**MINIMUM ORDERS:** Minimum order is \$15.00.

**SPECIFICATIONS:** Tennsco reserves the right to change any product specifications contained in this price list.

**WEIGHT:** Weights shown are approximate.

**FREIGHT CLAIMS:** Claims for shortages must be made in writing to the Home Office within 15 days from receipt of shipment. Claims for damaged or lost material must be filed with the carrier.

**PARTIAL SHIPMENTS:** Tennsco reserves the right to make delivery in installments unless otherwise expressly stated herein. All such installments shall be separately invoiced and paid for when due, without regard to subsequent deliveries. Delay in delivery of all installments shall not relieve Buyer of its obligations to accept remaining deliveries.

**Caution:** When you give delivering carrier a clear receipt for a shipment in which there is damaged merchandise or a shortage, the carrier is relieved of further responsibility. Claims for damage or shortage must be filed by you with the delivering carrier. Tennsco will not accept return of merchandise damaged in transit. Your claim is with the delivering carrier.

**SHIPPING TIME:** Shipping dates are estimates only, based on standard manufacturing times. Tennsco makes every effort to meet shipping date requests, but will not be held liable for missed shipping dates. Once items are shipped, Tennsco is not responsible for delays caused by the delivering carrier. This includes, but is not limited to, delays in installation proceedings due to slow delivery by carrier.

**CANCELLATIONS & RETURNS:** Orders for "Special" items are not subject to change or cancellation. No return merchandise will be accepted without written consent of the General Office, Dickson, Tennessee. All returned shipments are subject to a handling charge of 25% plus all transportation charges incurred by Tennsco unless Tennsco is at fault. Once production of "Special" items has begun, cancellation of order is subject to Tennsco approval. A 15% surcharge will be assessed to approved cancelled items.

**CODE RESTRICTIONS:** Local building codes vary. It is the purchaser's responsibility to determine that product installation is in accordance with local requirements.

## LIMITED WARRANTY

Tennsco warrants goods purchased hereunder to be free of defects in materials and workmanship for a period of one (1) year from the date of shipment, hereunder. Tennsco's warranty shall not apply in the event goods are damaged as a result of misuse, abuse, neglect, accident, improper application, modification or repair by persons not authorized by Seller, where goods are damaged during shipment. UNLESS CONSIDERED UNENFORCEABLE OR UNLAWFUL UNDER APPLICABLE LAW:

- a. ALL IMPLIED WARRANTIES, INCLUDING BUT NOT LIMITED TO WARRANTIES OR MERCHANTABILITY AND FITNESS FOR A PARTICULAR PURPOSE ARE HEREBY EXCLUDED:
- b. BUYERS REMEDY, IF ANY, FOR ANY DEFECTIVE GOODS SHALL BE LIMITED TO A REFUND BY SELLER OR REPLACEMENT OF THE GOODS AT SELLER'S OPTION, AND SHALL IN NO EVENT INCLUDE DAMAGES OF ANY KIND, WHETHER INCIDENTAL, CONSEQUENTIAL OR OTHERWISE.

NO GOODS ACCEPTED FOR RETURN WITHOUT PRIOR APPROVAL. Seller shall have the right to inspect any goods claimed to be defective at Buyer's place of business or require Buyer to return the goods to Seller for inspection on Seller's premises. Transportation charges covering returned goods will be borne by Seller only if such goods are proven to be defective, are covered by this warranty and are returned within the warranty period stated above.

TENNSCO CORP.  
201 TENNSCO DRIVE  
DICKSON, TN 37056-1888  
(615) 446-8000 (800) 251-8184  
FAX: (800) 722-0134

# ESTEY®

DIVISION OF TENNSCO CORP.

## LIBRARY SHELVING 2-INCH WELD FRAME

## PRICE LIST

DIVISION OF TENNSCO CORP.  
201 TENNSCO DRIVE  
DICKSON, TN 37056-1888  
(615) 446-8000 (800) 251-8184  
FACSIMILE: (800) 722-0134  
WEB PAGE: <http://www.tennsco.com>

**EFFECTIVE JUNE 1, 2011**

**This price list supersedes all previous price lists.  
Prices subject to change without notice.**

## CONTENTS:

### Introduction:

- PAGE 2: Features and standard colors  
PAGE 3: About the weld frame system

### Weld Frame Units:

- PAGES 4-5: Shelving units - 36" wide  
PAGES 6-7: Divider units - 36" wide  
PAGES 8-9: Integral back units - 36" wide  
PAGE 10: Display units  
PAGE 11: Frames & frame accessories  
PAGES 12-13: Base shelves  
PAGE 14: Shelves, brackets, dividers, shims

### Accessories

- PAGE 15: Book carts, book trucks  
PAGE 16: Periodical display, sloped display, storage, and integral back shelves  
PAGE 17: Storage shelves, reference shelves, face-out display shelf, audio-video shelves, zig-zag shelves  
PAGE 18: Cabinets, trays, newspaper and media rack, work shelf, browsing box  
PAGE 19: Wall hung columns, overhead bracing, wall clip, labeling accessories  
PAGE 20: Book supports, fillers, tilt brackets  
PAGE 21: Backstops, base filler closures  
PAGE 22: Canopy tops & accessories, lighting  
PAGE 23: Gussets and fillers  
PAGE 24: End panels and backs

# ESTEY SHELVING

## **FUNCTION—**

Estey library shelving offers you superior strength while saving valuable space. This is a shelving system designed to work. A shelving system that continues to perform well after years of rigorous library use.

## **VERSATILITY—**

All Estey components are interchangeable. Putting together your own configuration is as simple as arranging the individual elements. The modular design lets you seamlessly build specialty items right into the system.

## **AESTHETICS—**

Estey library shelving is an open canvas. You choose the paint colors and wood finishes (supplied by local Estey Dealer) that best expresses your vision and complements your architecture. The clean, sleek look of Estey shelving blends in with any decor.

---

## **STANDARD COLORS—**

Estey products are painted with a baked-on powder coated finish. All metal parts are thoroughly cleaned with five-stage iron phosphate under finish. The chart below represents Estey standard colors only. Special color matches can be furnished; contact factory for pricing. Touchup paint may also be ordered using the chart below.

CAT. NO.	STANDARD COLORS	WEIGHT	PRICE
P-1	Arctic White #061	0.5	<b>23.00</b>
LTUP-1	Autumn White #564	0.5	<b>23.00</b>
P-2	Black #003	0.5	<b>23.00</b>
LTUP-1	Champagne/Putty #216	0.5	<b>23.00</b>
LTUP-1	Dove Grey #074	0.5	<b>23.00</b>
P-10	Georgian Ivory #062	0.5	<b>23.00</b>
LTUP-1	Light Grey #053	0.5	<b>23.00</b>
LTUP-1	Medium Grey #002	0.5	<b>23.00</b>
LTUP-1	Oyster #470	0.5	<b>23.00</b>
P-5	Pearl Grey #065	0.5	<b>23.00</b>
LTUP-1	Sand #214	0.5	<b>23.00</b>
P-8	Sandstone #068	0.5	<b>23.00</b>

**NOTE—** Estey can provide an antimicrobial coating on shelving. Contact customer service for information and pricing.

## THE 2" WELD FRAME SYSTEM

**Estey Weld Frame** construction eliminates the need for sway bracing and separate starter/adder units. It permits complete file-through capability in all shelving units.

**Weld frames offered in this price list are 2" deep. A 2-1/2" weld frame is also available; contact factory for price list.**

### All Units Feature:

- Upright slot spacing 1" on centers in a 6" repeat pattern.
- Upright halves with 4 right angle bends.
- Six-point leveling system per double-face section; four-point leveling system per single face section (adjustable levelers provided on fixed and adjustable base units).
- Base shelves available in one-piece pan, or in multiple-piece construction with kickplate.
- Electrostatically applied/baked-on powder epoxy.

### Basic Shelving Components:

- Welded frames
- Base brackets
- Base shelf
- Adjustable shelves and brackets
- Kickplate(s) (black powder coat finish)

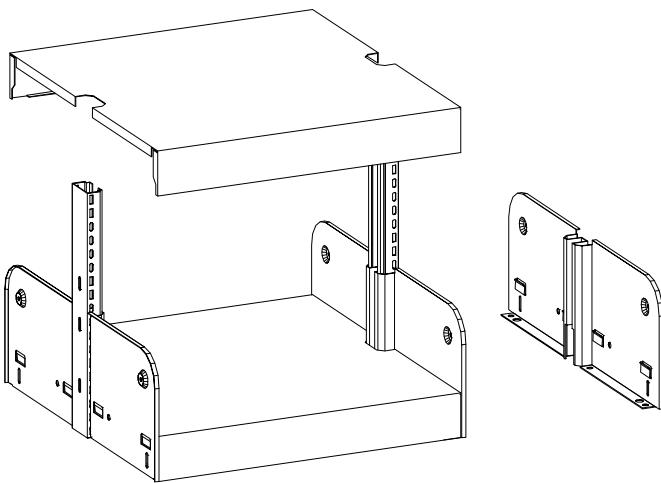

**FIXED BASE SHELF**

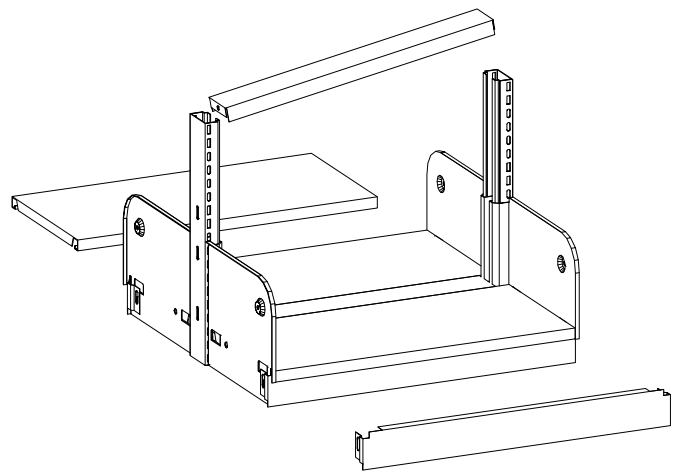

**ADJUSTABLE (KICKPLATE)  
BASE SHELF**

**NOTE: All shelf depths in this catalog are expressed in nominal sizes. Base shelf dimensions will actually be greater than those shown; all other shelf sizes will be 1" less. Contact factory for specific dimensions.**

**SINGLE FACE\***

\*All single face shelving must be wall anchored.



FIXED BASE			ADJUSTABLE BASE			SHELF DEPTH	BASE DEPTH
CAT. NO.	WT.	PRICE	CAT. NO.	WT.	PRICE		
<b>42" HIGH, 3 LEVELS</b>							
W2F41080	42	<b>254.00</b>	W2A41080	42	<b>232.00</b>	8"	8"
W2F41082	44	<b>244.00</b>	W2A41082	44	<b>235.00</b>	8"	10"
W2F41090	44	<b>266.00</b>	W2A41090	45	<b>244.00</b>	9"	9"
W2F41091	46	<b>252.00</b>	W2A41091	46	<b>244.00</b>	9"	10"
W2F41100	47	<b>258.00</b>	W2A41100	47	<b>250.00</b>	10"	10"
W2F41102	48	<b>262.00</b>	W2A41102	49	<b>254.00</b>	10"	12"
W2F41120	51	<b>272.00</b>	W2A41120	52	<b>263.00</b>	12"	12"
<b>66" HIGH, 5 LEVELS</b>							
W2F61080	60	<b>330.00</b>	W2A61080	60	<b>308.00</b>	8"	8"
W2F61082	62	<b>320.00</b>	W2A61082	62	<b>311.00</b>	8"	10"
W2F61090	64	<b>351.00</b>	W2A61090	65	<b>328.00</b>	9"	9"
W2F61091	65	<b>336.00</b>	W2A61091	65	<b>328.00</b>	9"	10"
W2F61100	68	<b>348.00</b>	W2A61100	68	<b>340.00</b>	10"	10"
W2F61102	69	<b>353.00</b>	W2A61102	70	<b>344.00</b>	10"	12"
W2F61120	75	<b>372.00</b>	W2A61120	76	<b>363.00</b>	12"	12"
<b>78" HIGH, 6 LEVELS</b>							
W2F71080	69	<b>368.00</b>	W2A71080	69	<b>345.00</b>	8"	8"
W2F71082	71	<b>358.00</b>	W2A71082	71	<b>349.00</b>	8"	10"
W2F71090	73	<b>393.00</b>	W2A71090	75	<b>369.00</b>	9"	9"
W2F71091	75	<b>379.00</b>	W2A71091	75	<b>369.00</b>	9"	10"
W2F71100	79	<b>394.00</b>	W2A71100	79	<b>384.00</b>	10"	10"
W2F71102	80	<b>398.00</b>	W2A71102	80	<b>388.00</b>	10"	12"
W2F71120	88	<b>422.00</b>	W2A71120	88	<b>413.00</b>	12"	12"
<b>84" HIGH, 7 LEVELS</b>							
W2F81080	77	<b>400.00</b>	W2A81080	77	<b>378.00</b>	8"	8"
W2F81082	79	<b>390.00</b>	W2A81082	79	<b>381.00</b>	8"	10"
W2F81090	82	<b>429.00</b>	W2A81090	83	<b>406.00</b>	9"	9"
W2F81091	83	<b>415.00</b>	W2A81091	84	<b>407.00</b>	9"	10"
W2F81100	88	<b>433.00</b>	W2A81100	88	<b>425.00</b>	10"	10"
W2F81102	89	<b>437.00</b>	W2A81102	90	<b>429.00</b>	10"	12"
W2F81120	98	<b>466.00</b>	W2A81120	99	<b>457.00</b>	12"	12"
<b>90" HIGH, 7 LEVELS</b>							
W2F91080	78	<b>405.00</b>	W2A91080	78	<b>383.00</b>	8"	8"
W2F91082	80	<b>395.00</b>	W2A91082	81	<b>386.00</b>	8"	10"
W2F91090	84	<b>434.00</b>	W2A91090	85	<b>411.00</b>	9"	9"
W2F91091	85	<b>420.00</b>	W2A91091	85	<b>412.00</b>	9"	10"
W2F91100	90	<b>438.00</b>	W2A91100	90	<b>430.00</b>	10"	10"
W2F91102	91	<b>442.00</b>	W2A91102	91	<b>434.00</b>	10"	12"
W2F91120	100	<b>471.00</b>	W2A91120	100	<b>462.00</b>	12"	12"

24" and 30" wide units are also available. Contact factory for pricing and weights.  
For 24" units, add "2" to end of catalog number (e.g. W2F810802); for 30" units, add "3" (e.g. W2F810803).

# SHELVING UNITS - 36" WIDE FIXED AND ADJUSTABLE BASE

**ESTEY**  
DIVISION OF TENNSCO CORP.

## DOUBLE FACE

FIXED BASE			ADJUSTABLE BASE			SHELF DEPTH	BASE DEPTH
CAT. NO.	WT.	PRICE	CAT. NO.	WT.	PRICE		
<b>42" HIGH, 3 LEVELS</b>							
W2F42080	61	315.00	W2A42080	64	332.00	8"	16"
W2F42082	65	329.00	W2A42082	68	338.00	8"	20"
W2F42090	66	343.00	W2A42090	69	357.00	9"	18"
W2F42091	68	346.00	W2A42091	71	355.00	9"	20"
W2F42100	71	358.00	W2A42100	74	367.00	10"	20"
W2F42102	74	372.00	W2A42102	79	377.00	10"	24"
W2F42120	80	391.00	W2A42120	83	396.00	12"	24"
<b>66" HIGH, 5 LEVELS</b>							
W2F62080	92	449.00	W2A62080	96	466.00	8"	16"
W2F62082	96	463.00	W2A62082	99	472.00	8"	20"
W2F62090	100	494.00	W2A62090	103	508.00	9"	18"
W2F62091	102	497.00	W2A62091	106	506.00	9"	20"
W2F62100	108	521.00	W2A62100	112	530.00	10"	20"
W2F62102	112	535.00	W2A62102	115	540.00	10"	24"
W2F62120	124	573.00	W2A62120	127	578.00	12"	24"
<b>78" HIGH, 6 LEVELS</b>							
W2F72080	108	576.00	W2A72080	112	533.00	8"	16"
W2F72082	112	530.00	W2A72082	115	540.00	8"	20"
W2F72090	118	569.00	W2A72090	121	583.00	9"	18"
W2F72091	118	572.00	W2A72091	123	581.00	9"	20"
W2F72100	127	602.00	W2A72100	131	611.00	10"	20"
W2F72102	131	616.00	W2A72102	134	621.00	10"	24"
W2F72120	146	664.00	W2A72120	149	669.00	12"	24"
<b>84" HIGH, 7 LEVELS</b>							
W2F82080	123	577.00	W2A82080	126	594.00	8"	16"
W2F82082	128	591.00	W2A82082	130	600.00	8"	20"
W2F82090	134	639.00	W2A82090	137	653.00	9"	18"
W2F82091	135	642.00	W2A82091	139	651.00	9"	20"
W2F82100	145	678.00	W2A82100	148	687.00	10"	20"
W2F82102	148	692.00	W2A82102	151	697.00	10"	24"
W2F82120	166	749.00	W2A82120	169	754.00	12"	24"
<b>90" HIGH, 7 LEVELS</b>							
W2F92080	124	582.00	W2A92080	128	599.00	8"	16"
W2F92082	128	596.00	W2A92082	131	605.00	8"	20"
W2F92090	135	644.00	W2A92090	138	658.00	9"	18"
W2F92091	137	647.00	W2A92091	141	656.00	9"	20"
W2F92100	146	683.00	W2A92100	151	692.00	10"	20"
W2F92102	149	697.00	W2A92102	152	702.00	10"	24"
W2F92120	168	754.00	W2A92120	172	759.00	12"	24"



24" and 30" wide units are also available. Contact factory for pricing and weights.  
For 24" units, add "2" to end of catalog number (e.g. W2F820802); for 30" units, add "3" (e.g. W2F820803).



# ESTEY<sup>®</sup> INTEGRAL BACK DIVIDER UNITS, 36" WIDE FIXED & ADJUSTABLE BASE

DIVISION OF TENNSCO CORP.

## SINGLE FACE\*

\*All single face shelving must be wall anchored.

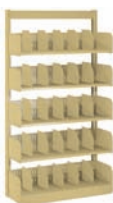

FIXED BASE			ADJUSTABLE BASE			SHELF DEPTH	BASE DEPTH
CAT. NO.	WT.	PRICE	CAT. NO.	WT.	PRICE		
<b>42" HIGH, 3 LEVELS</b>							
W2BDF41100	63	<b>340.00</b>	W2BDA41100	63	<b>345.00</b>	10"	10"
W2BDF41102	64	<b>347.00</b>	W2BDA41102	65	<b>350.00</b>	10"	12"
W2BDF41103	65	<b>356.00</b>	W2BDA41103	66	<b>361.00</b>	10"	13"
W2BDF41120	67	<b>358.00</b>	W2BDA41120	68	<b>362.00</b>	12"	12"
W2BDF41130	70	<b>379.00</b>	W2BDA41130	70	<b>385.00</b>	13"	13"
W2BDF41133	79	<b>403.00</b>	W2BDA41133	74	<b>414.00</b>	13"	16"
<b>66" HIGH, 5 LEVELS</b>							
W2BDF61100	96	<b>500.00</b>	W2BDA61100	96	<b>505.00</b>	10"	10"
W2BDF61102	97	<b>506.00</b>	W2BDA61102	98	<b>510.00</b>	10"	12"
W2BDF61103	98	<b>515.00</b>	W2BDA61103	99	<b>520.00</b>	10"	13"
W2BDF61120	103	<b>529.00</b>	W2BDA61120	104	<b>533.00</b>	12"	12"
W2BDF61130	107	<b>562.00</b>	W2BDA61130	111	<b>583.00</b>	13"	13"
W2BDF61133	116	<b>586.00</b>	W2BDA61133	111	<b>597.00</b>	13"	16"
<b>78" HIGH, 6 LEVELS</b>							
W2BDF71100	112	<b>580.00</b>	W2BDA71100	113	<b>584.00</b>	10"	10"
W2BDF71102	114	<b>586.00</b>	W2BDA71102	114	<b>589.00</b>	10"	12"
W2BDF71103	114	<b>595.00</b>	W2BDA71103	115	<b>600.00</b>	10"	13"
W2BDF71120	121	<b>615.00</b>	W2BDA71120	122	<b>618.00</b>	12"	12"
W2BDF71130	126	<b>654.00</b>	W2BDA71130	127	<b>659.00</b>	13"	13"
W2BDF71133	135	<b>678.00</b>	W2BDA71133	130	<b>688.00</b>	13"	16"
<b>84" HIGH, 7 LEVELS</b>							
W2BDF81100	127	<b>653.00</b>	W2BDA81100	128	<b>658.00</b>	10"	10"
W2BDF81102	129	<b>659.00</b>	W2BDA81102	129	<b>663.00</b>	10"	12"
W2BDF81103	130	<b>669.00</b>	W2BDA81103	130	<b>674.00</b>	10"	13"
W2BDF81120	138	<b>694.00</b>	W2BDA81120	139	<b>698.00</b>	12"	12"
W2BDF81130	143	<b>739.00</b>	W2BDA81130	144	<b>745.00</b>	13"	13"
W2BDF81133	153	<b>763.00</b>	W2BDA81133	148	<b>774.00</b>	13"	16"
<b>90" HIGH, 7 LEVELS</b>							
W2BDF91100	129	<b>658.00</b>	W2BDA91100	130	<b>663.00</b>	10"	10"
W2BDF91102	130	<b>664.00</b>	W2BDA91102	131	<b>668.00</b>	10"	12"
W2BDF91103	131	<b>674.00</b>	W2BDA91103	132	<b>679.00</b>	10"	13"
W2BDF91120	139	<b>699.00</b>	W2BDA91120	140	<b>703.00</b>	12"	12"
W2BDF91130	145	<b>744.00</b>	W2BDA91130	146	<b>750.00</b>	13"	13"
W2BDF91133	154	<b>768.00</b>	W2BDA91133	149	<b>777.00</b>	13"	16"
<b>93" HIGH, 8 LEVELS</b>							
W2BDF01100	144	<b>776.00</b>	W2BDA01100	144	<b>781.00</b>	10"	10"
W2BDF01102	145	<b>782.00</b>	W2BDA01102	146	<b>786.00</b>	10"	12"
W2BDF01103	146	<b>791.00</b>	W2BDA01103	146	<b>796.00</b>	10"	13"
W2BDF01120	155	<b>823.00</b>	W2BDA01120	156	<b>826.00</b>	12"	12"
W2BDF01130	162	<b>874.00</b>	W2BDA01130	163	<b>879.00</b>	13"	13"
W2BDF01133	171	<b>898.00</b>	W2BDA01133	175	<b>1,016.00</b>	13"	16"

All divider units come with 5 dividers per shelf.

24" and 30" wide units are also available. Contact factory for pricing and weights. For 24" units, add "2" to end of catalog number (e.g. W2BDF811002); for 30" units, add "3" (e.g. W2BDF811003).

# INTEGRAL BACK DIVIDER UNITS, 36" WIDE **ESTEY**<sup>®</sup> FIXED AND ADJUSTABLE BASE

DIVISION OF TENNSCO CORP.

## DOUBLE FACE

FIXED BASE			ADJUSTABLE BASE			SHELF DEPTH	BASE DEPTH
CAT. NO.	WT.	PRICE	CAT. NO.	WT.	PRICE		
<b>42" HIGH, 3 LEVELS</b>							
W2BDF42100	106	558.00	W2BDA42100	108	566.00	10"	20"
W2BDF42102	110	574.00	W2BDA42102	111	578.00	10"	24"
W2BDF42103	112	588.00	W2BDA42103	113	596.00	10"	26"
W2BDF42120	116	597.00	W2BDA42120	117	601.00	12"	24"
W2BDF42130	121	635.00	W2BDA42130	122	643.00	13"	26"
W2BDF42133	129	679.00	W2BDA42133	127	691.00	13"	32"
<b>66" HIGH, 5 LEVELS</b>							
W2BDF62100	168	859.00	W2BDA62100	169	859.00	10"	20"
W2BDF62102	171	875.00	W2BDA62102	172	879.00	10"	24"
W2BDF62103	173	889.00	W2BDA62103	174	897.00	10"	26"
W2BDF62120	183	921.00	W2BDA62120	184	925.00	12"	24"
W2BDF62130	191	983.00	W2BDA62130	192	991.00	13"	26"
W2BDF62133	199	1,027.00	W2BDA62133	206	1,145.00	13"	32"
<b>78" HIGH, 6 LEVELS</b>							
W2BDF72100	198	1,009.00	W2BDA72100	200	1,017.00	10"	20"
W2BDF72102	202	1,025.00	W2BDA72102	203	1,029.00	10"	24"
W2BDF72103	204	1,039.00	W2BDA72103	205	1,047.00	10"	26"
W2BDF72120	217	1,083.00	W2BDA72120	218	1,087.00	12"	24"
W2BDF72130	226	1,157.00	W2BDA72130	228	1,165.00	13"	26"
W2BDF72133	234	1,201.00	W2BDA72133	236	1,227.00	13"	32"
<b>84" HIGH, 7 LEVELS</b>							
W2BDF82100	228	1,154.00	W2BDA82100	229	1,162.00	10"	20"
W2BDF82102	231	1,170.00	W2BDA82102	232	1,174.00	10"	24"
W2BDF82103	233	1,184.00	W2BDA82103	234	1,192.00	10"	26"
W2BDF82120	249	1,239.00	W2BDA82120	249	1,235.00	12"	24"
W2BDF82130	260	1,325.00	W2BDA82130	262	1,333.00	13"	26"
W2BDF82133	268	1,369.00	W2BDA82133	270	1,395.00	13"	32"
<b>90" HIGH, 7 LEVELS</b>							
W2BDF92100	229	1,159.00	W2BDA92100	231	1,167.00	10"	20"
W2BDF92102	232	1,175.00	W2BDA92102	233	1,179.00	10"	24"
W2BDF92103	224	1,189.00	W2BDA92103	235	1,197.00	10"	26"
W2BDF92120	251	1,244.00	W2BDA92120	252	1,248.00	12"	24"
W2BDF92130	262	1,330.00	W2BDA92130	263	1,338.00	13"	26"
W2BDF92133	270	1,374.00	W2BDA92133	271	1,400.00	13"	32"
<b>93" HIGH, 8 LEVELS</b>							
W2BDF02100	258	1,347.00	W2BDA02100	259	1,355.00	10"	20"
W2BDF02102	261	1,363.00	W2BDA02102	262	1,367.00	10"	24"
W2BDF02103	263	1,377.00	W2BDA02103	264	1,385.00	10"	26"
W2BDF02120	283	1,444.00	W2BDA02120	284	1,448.00	12"	24"
W2BDF02130	291	1,506.00	W2BDA02130	296	1,550.00	13"	26"
W2BDF02133	303	1,586.00	W2BDA02133	304	1,612.00	13"	32"



24" and 30" wide units are also available. Contact factory for pricing and weights. For 24" units, add "2" to end of catalog number (e.g. W2BDF821002); for 30" units, add "3" (e.g. W2BDF821003).

All divider units come with 5 dividers per shelf.

**INTEGRAL BACK UNITS, 36" WIDE  
FIXED & ADJUSTABLE BASE**

**SINGLE FACE\***

\*All single face shelving must be wall anchored.



FIXED BASE			ADJUSTABLE BASE			SHELF DEPTH	BASE DEPTH
CAT. NO.	WT.	PRICE	CAT. NO.	WT.	PRICE		
<b>42" HIGH, 3 LEVELS</b>							
W2FIB41080	43	<b>278.00</b>	W2AIB41080	43	<b>265.00</b>	8"	8"
W2FIB41082	45	<b>279.00</b>	W2AIB41082	45	<b>266.00</b>	8"	10"
W2FIB41090	45	<b>287.00</b>	W2AIB41090	46	<b>273.00</b>	9"	9"
W2FIB41091	46	<b>285.00</b>	W2AIB41091	47	<b>273.00</b>	9"	10"
W2FIB41100	48	<b>289.00</b>	W2AIB41100	48	<b>276.00</b>	10"	10"
W2FIB41102	49	<b>296.00</b>	W2AIB41102	50	<b>283.00</b>	10"	12"
W2FIB41120	52	<b>310.00</b>	W2AIB41120	53	<b>296.00</b>	12"	12"
<b>66" HIGH, 5 LEVELS</b>							
W2FIB61080	62	<b>381.00</b>	W2AIB61080	62	<b>369.00</b>	8"	8"
W2FIB61082	64	<b>382.00</b>	W2AIB61082	65	<b>370.00</b>	8"	10"
W2FIB61090	66	<b>397.00</b>	W2AIB61090	67	<b>383.00</b>	9"	9"
W2FIB61091	67	<b>394.00</b>	W2AIB61091	68	<b>382.00</b>	9"	10"
W2FIB61100	70	<b>402.00</b>	W2AIB61100	71	<b>390.00</b>	10"	10"
W2FIB61102	72	<b>410.00</b>	W2AIB61102	72	<b>396.00</b>	10"	12"
W2FIB61120	78	<b>437.00</b>	W2AIB61120	79	<b>424.00</b>	12"	12"
<b>78" HIGH, 6 LEVELS</b>							
W2FIB71080	72	<b>433.00</b>	W2AIB71080	72	<b>420.00</b>	8"	8"
W2FIB71082	74	<b>434.00</b>	W2AIB71082	75	<b>422.00</b>	8"	10"
W2FIB71090	77	<b>451.00</b>	W2AIB71090	78	<b>437.00</b>	9"	9"
W2FIB71091	78	<b>449.00</b>	W2AIB71091	78	<b>436.00</b>	9"	10"
W2FIB71100	82	<b>459.00</b>	W2AIB71100	82	<b>446.00</b>	10"	10"
W2FIB71102	83	<b>466.00</b>	W2AIB71102	84	<b>452.00</b>	10"	12"
W2FIB71120	92	<b>501.00</b>	W2AIB71120	93	<b>487.00</b>	12"	12"
<b>84" HIGH, 7 LEVELS</b>							
W2FIB81080	81	<b>479.00</b>	W2AIB81080	81	<b>466.00</b>	8"	8"
W2FIB81082	83	<b>480.00</b>	W2AIB81082	83	<b>468.00</b>	8"	10"
W2FIB81090	86	<b>500.00</b>	W2AIB81090	87	<b>486.00</b>	9"	9"
W2FIB81091	87	<b>498.00</b>	W2AIB81091	88	<b>486.00</b>	9"	10"
W2FIB81100	92	<b>510.00</b>	W2AIB81100	92	<b>498.00</b>	10"	10"
W2FIB81102	93	<b>517.00</b>	W2AIB81102	94	<b>504.00</b>	10"	12"
W2FIB81120	104	<b>559.00</b>	W2AIB81120	104	<b>545.00</b>	12"	12"
<b>90" HIGH, 7 LEVELS</b>							
W2FIB91080	82	<b>484.00</b>	W2AIB91080	83	<b>472.00</b>	8"	8"
W2FIB91082	84	<b>485.00</b>	W2AIB91082	85	<b>473.00</b>	8"	10"
W2FIB91090	87	<b>505.00</b>	W2AIB91090	89	<b>491.00</b>	9"	9"
W2FIB91091	89	<b>503.00</b>	W2AIB91091	89	<b>491.00</b>	9"	10"
W2FIB91100	93	<b>515.00</b>	W2AIB91100	94	<b>503.00</b>	10"	10"
W2FIB91102	95	<b>522.00</b>	W2AIB91102	95	<b>509.00</b>	10"	12"
W2FIB91120	105	<b>564.00</b>	W2AIB91120	106	<b>550.00</b>	12"	12"

Units come with one wire divider per shelf level.

24" and 30" wide units are also available; contact factory for pricing and weights. For 24" units, add "2" to end of catalog number (e.g. W2FIB810802); for 30" units, add "3" (e.g. W2FIB810803).



# INTEGRAL BACK UNITS, 36" WIDE FIXED AND ADJUSTABLE BASE

**ESTEY**  
DIVISION OF TENNSCO CORP.

## DOUBLE FACE

FIXED BASE			ADJUSTABLE BASE			SHELF DEPTH	BASE DEPTH
CAT. NO.	WT.	PRICE	CAT. NO.	WT.	PRICE		
<b>42" HIGH, 3 LEVELS</b>							
W2FIB42080	66	427.00	W2AIB42080	68	407.00	8"	16"
W2FIB42082	70	435.00	W2AIB42082	71	409.00	8"	20"
W2FIB42090	71	445.00	W2AIB42090	72	425.00	9"	18"
W2FIB42091	73	447.00	W2AIB42091	74	421.00	9"	20"
W2FIB42100	76	455.00	W2AIB42100	77	429.00	10"	20"
W2FIB42102	80	473.00	W2AIB42102	81	443.00	10"	24"
W2FIB42120	87	500.00	W2AIB42120	88	471.00	12"	24"
<b>66" HIGH, 5 LEVELS</b>							
W2FIB62080	101	616.00	W2AIB62080	102	596.00	8"	16"
W2FIB62082	104	624.00	W2AIB62082	106	598.00	8"	20"
W2FIB62090	109	646.00	W2AIB62090	110	626.00	9"	18"
W2FIB62091	110	648.00	W2AIB62091	112	622.00	9"	20"
W2FIB62100	117	664.00	W2AIB62100	118	638.00	10"	20"
W2FIB62102	120	682.00	W2AIB62102	121	652.00	10"	24"
W2FIB62120	134	737.00	W2AIB62120	135	707.00	12"	24"
<b>78" HIGH, 6 LEVELS</b>							
W2FIB72080	118	710.00	W2AIB72080	120	691.00	8"	16"
W2FIB72082	122	718.00	W2AIB72082	123	693.00	8"	20"
W2FIB72090	128	746.00	W2AIB72090	129	727.00	9"	18"
W2FIB72091	129	748.00	W2AIB72091	131	723.00	9"	20"
W2FIB72100	137	768.00	W2AIB72100	139	743.00	10"	20"
W2FIB72102	141	787.00	W2AIB72102	142	757.00	10"	24"
W2FIB72120	158	856.00	W2AIB72120	159	826.00	12"	24"
<b>84" HIGH, 7 LEVELS</b>							
W2FIB82080	134	799.00	W2AIB82080	136	779.00	8"	16"
W2FIB82082	138	807.00	W2AIB82082	139	781.00	8"	20"
W2FIB82090	145	841.00	W2AIB82090	146	821.00	9"	18"
W2FIB82091	147	843.00	W2AIB82091	149	817.00	9"	20"
W2FIB82100	156	867.00	W2AIB82100	158	841.00	10"	20"
W2FIB82102	160	885.00	W2AIB82102	161	855.00	10"	24"
W2FIB82120	181	968.00	W2AIB82120	182	938.00	12"	24"
<b>90" HIGH, 7 LEVELS</b>							
W2FIB92080	136	804.00	W2AIB92080	137	784.00	8"	16"
W2FIB92082	139	812.00	W2AIB92082	141	786.00	8"	20"
W2FIB92090	147	846.00	W2AIB92090	148	826.00	9"	18"
W2FIB92091	149	848.00	W2AIB92091	150	822.00	9"	20"
W2FIB92100	158	872.00	W2AIB92100	159	846.00	10"	20"
W2FIB92102	161	890.00	W2AIB92102	162	860.00	10"	24"
W2FIB92120	182	973.00	W2AIB92120	183	943.00	12"	24"



Units come with one wire divider per shelf level.

24" and 30" wide units are also available. Contact factory for pricing and weights. For 24" units, add "2" to end of catalog number (e.g. W2FIB820802); for 30" units, add "3" (e.g. W2FIB820803).

**PERIODICAL DISPLAY UNITS**

Pivoting periodical shelving with flat storage shelf. With 12" storage shelves & 12" fixed base single face or 24" fixed base double face.



\* All single face shelving must be wall anchored.

\*\* Overhead top bracing recommended. 24" wide units are also available. Contact factory for pricing and weights.

CATALOG NUMBER	SLOPING SHELVES	STORAGE LEVELS	W	D	H	WT.	PRICE
<b>SINGLE FACE *</b>							
W2P411203	3	3	30	12	42	67	<b>418.00</b>
W2P611203	4	4	30	12	66	87	<b>525.00</b>
W2P711203	5	5	30	12	78	105	<b>624.00</b>
W2P811203	5	5	30	12	84	122	<b>627.00</b>
W2P911203	6	6	30	12	90	123	<b>721.00</b>
W2P41120	3	3	36	12	42	76	<b>418.00</b>
W2P61120	4	4	36	12	66	99	<b>525.00</b>
W2P71120	5	5	36	12	78	119	<b>624.00</b>
W2P81120	5	5	36	12	84	138	<b>627.00</b>
W2P91120	6	6	36	12	90	140	<b>721.00</b>
<b>DOUBLE FACE</b>							
W2P421203	6	6	30	24	42	114	<b>678.00</b>
W2P621203	8	8	30	24	66	149	<b>875.00</b>
W2P721203	10	10	30	24	78	183	<b>1,062.00</b>
W2P821203	10	10	30	24	84	215	<b>1,066.00</b>
W2P921203**	12	12	30	24	90	216	<b>1,249.00</b>
W2P42120	6	6	36	24	42	130	<b>678.00</b>
W2P62120	8	8	36	24	66	171	<b>875.00</b>
W2P72120	10	10	36	24	78	209	<b>1,062.00</b>
W2P82120	10	10	36	24	84	246	<b>1,066.00</b>
W2P92120**	12	12	36	24	90	248	<b>1,249.00</b>

**DISPLAY SHELF UNITS\*** (\*available with 2-1/2 inch welded frame only)

Ideal for displaying various periodicals, new books, or other media items. Lower shelves are sloped 10° for better visualization.



SINGLE FACE

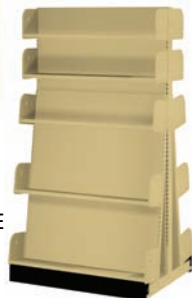

DOUBLE FACE

\* All single face shelving must be wall anchored.

\*\* Overhead top bracing recommended. 24" and 30" wide units also available. Contact factory for pricing and weights.

CATALOG NUMBER	LEVEL SHELVES	SLOPING SHELVES	W	D	H	WT.	PRICE
<b>SINGLE FACE *</b>							
DAS436	0	3	36	17	42	64	<b>461.00</b>
DAS636	2	3	36	17	66	98	<b>618.00</b>
DAS836	3	4	36	17	84	127	<b>731.00</b>
DAS936 **	3	4	36	17	90	130	<b>750.00</b>
<b>DOUBLE FACE</b>							
DAD436	0	6	36	31	42	111	<b>692.00</b>
DAD636	4	6	36	31	66	174	<b>986.00</b>
DAD836	6	8	36	31	84	226	<b>1,198.00</b>
DAD936 **	6	8	36	31	90	235	<b>1,231.00</b>

# FRAMES, FRAME ACCESSORIES

**ESTEY**  
DIVISION OF TENNSCO CORP.

CAT. NO.	DESCRIPTION	W	D	H	WT.	PRICE
W2-4230		30	2	42	15	<b>93.00</b>
W2-5430		30	2	54	17	<b>108.00</b>
W2-6630		30	2	66	19	<b>111.00</b>
W2-7830		30	2	78	22	<b>120.00</b>
W2-8430		30	2	84	23	<b>123.00</b>
W2-9030		30	2	90	24	<b>128.00</b>
W2-9330		30	2	93	25	<b>175.00</b>
W2-4236		36	2	42	16	<b>93.00</b>
W2-5436		36	2	54	18	<b>108.00</b>
W2-6636		36	2	66	21	<b>111.00</b>
W2-7836		36	2	78	23	<b>120.00</b>
W2-8436		36	2	84	24	<b>123.00</b>
W2-9036		36	2	90	26	<b>128.00</b>
W2-9336		36	2	93	26	<b>175.00</b>
W2-10836		36	2	108	29	<b>166.00</b>
W2-11236		36	2	112	30	<b>204.00</b>

## SEISMIC SWAY BRACES

SSBR6030A	For 66" and 78" frames	30	1	58	4.5	<b>64.00</b>
SSBR7330A	For 84", 90" and 93" frames	30	1	73	5.9	<b>81.00</b>
SSBR6036A	For 66" and 78" frames	36	1	58	4.5	<b>64.00</b>
SSBR7336A	For 84", 90" and 93" frames	36	1	73	5.9	<b>81.00</b>

Special widths or heights are available. Contact factory for pricing.

## WELDED FRAMES



WELDED FRAME



SEISMIC SWAY BRACES

## SEISMIC WELDED FRAMES

CAT. NO.	W	D	H	WT.	PRICE
SW2-7830	30	2	78	30	<b>192.00</b>
SW2-8430	30	2	84	31	<b>193.00</b>
SW2-9030	30	2	90	32	<b>197.00</b>
SW2-7836	36	2	78	32	<b>192.00</b>
SW2-8436	36	2	84	33	<b>193.00</b>
SW2-9036	36	2	90	35	<b>197.00</b>



Eliminates the need for sway braces.

## WELDED FRAME EXTENDER

CAT. NO.	W	D	H	WT.	PRICE
WFEXT2-3618	36	2	18	9.2	<b>137.00</b>
WFEXT2-3624	36	2	24	11.2	<b>107.00</b>
WFEXT2-3630	36	2	30	12.3	<b>120.00</b>
WFEXT2-36xx	36	2	Varies	Varies: contact factory	



Add to existing frames for more space. Available in a variety of sizes with a 12" minimum. Contact factory for pricing & weights on sizes not shown.

## CLOSED BASE SHELVES WITH AND WITHOUT DIVIDERS

### CLOSED BASE SHELVES (SINGLE FACE)

CAT. NO.	W	D	H	WT.	PRICE
<b>FOR FIXED BASE SHELVES</b>					
WB2-3608A	36	8	3 <sup>5</sup> / <sub>16</sub>	12.3	<b>100.00</b>
WB2-3609A	36	9	3 <sup>5</sup> / <sub>16</sub>	13.0	<b>103.00</b>
WB2-3610A	36	10	3 <sup>5</sup> / <sub>16</sub>	14.3	<b>89.00</b>
WB2-3612A	36	12	3 <sup>5</sup> / <sub>16</sub>	15.5	<b>93.00</b>
WB2-3613A	36	13	3 <sup>5</sup> / <sub>16</sub>	16.4	<b>116.00</b>
WB2-3616A	36	16	3 <sup>5</sup> / <sub>16</sub>	24.0	<b>131.00</b>
<b>FOR ADJUSTABLE BASE SHELVES</b>					
WA2-3608A	36	8	3 <sup>5</sup> / <sub>16</sub>	12.4	<b>78.00</b>
WA2-3609A	36	9	3 <sup>5</sup> / <sub>16</sub>	13.9	<b>81.00</b>
WA2-3610A	36	10	3 <sup>5</sup> / <sub>16</sub>	14.4	<b>82.00</b>
WA2-3612A	36	12	3 <sup>5</sup> / <sub>16</sub>	16.0	<b>86.00</b>
WA2-3613A	36	13	3 <sup>5</sup> / <sub>16</sub>	16.7	<b>96.00</b>
WA2-3616A	36	16	3 <sup>5</sup> / <sub>16</sub>	19.0	<b>105.00</b>

Comes complete with base brackets. Kickplates for adjustable base shelves are furnished with black powder coat finish. If 30" shelves are desired, change the number "36" to "30" (e.g. WA2-3013A or WB2-3013A). Call factory for prices and weights on 30" shelves.



### CLOSED BASE SHELVES (DOUBLE FACE)

CAT. NO.	W	D	H	WT.	PRICE
<b>FOR FIXED BASE SHELVES</b>					
WB2-3616DA	36	16	3 <sup>5</sup> / <sub>16</sub>	18	<b>105.00</b>
WB2-3618A	36	18	3 <sup>5</sup> / <sub>16</sub>	20	<b>116.00</b>
WB2-3620A	36	20	3 <sup>5</sup> / <sub>16</sub>	22	<b>119.00</b>
WB2-3624A	36	24	3 <sup>5</sup> / <sub>16</sub>	25	<b>133.00</b>
WB2-3626A	36	26	3 <sup>5</sup> / <sub>16</sub>	27	<b>170.00</b>
WB2-3632A	36	32	3 <sup>5</sup> / <sub>16</sub>	32	<b>194.00</b>
<b>FOR ADJUSTABLE BASE SHELVES</b>					
WA2-3616DA	36	16	3 <sup>5</sup> / <sub>16</sub>	21	<b>123.00</b>
WA2-3618A	36	18	3 <sup>5</sup> / <sub>16</sub>	23	<b>131.00</b>
WA2-3620A	36	20	3 <sup>5</sup> / <sub>16</sub>	25	<b>129.00</b>
WA2-3624A	36	24	3 <sup>5</sup> / <sub>16</sub>	28	<b>139.00</b>
WA2-3626A	36	26	3 <sup>5</sup> / <sub>16</sub>	30	<b>157.00</b>
WA2-3632A	36	32	3 <sup>5</sup> / <sub>16</sub>	35	<b>179.00</b>

Comes complete with base brackets. Kickplates for adjustable base shelves are furnished with black powder coat finish. If 30" shelves are desired, change the number "36" to "30" (e.g. WA2-3018A or WB2-3018A). Call factory for prices and weights on 30" shelves.

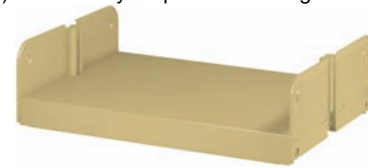

### CLOSED BASE SHELVES (SINGLE FACE) WITH INTEGRAL BACK & DIVIDERS

CAT. NO.	W	D	H	WT.	PRICE
<b>FOR FIXED BASE SHELVES</b>					
TBDF2-3610	36	10	3 <sup>5</sup> / <sub>16</sub>	18	<b>103.00</b>
TBDF2-3612	36	12	3 <sup>5</sup> / <sub>16</sub>	20	<b>109.00</b>
TBDF2-3613	36	13	3 <sup>5</sup> / <sub>16</sub>	20	<b>118.00</b>
TBDF2-3616	36	16	3 <sup>5</sup> / <sub>16</sub>	30	<b>142.00</b>
<b>FOR ADJUSTABLE BASE SHELVES</b>					
TBDA2-3610	36	10	3 <sup>5</sup> / <sub>16</sub>	19	<b>108.00</b>
TBDA2-3612	36	12	3 <sup>5</sup> / <sub>16</sub>	20	<b>113.00</b>
TBDA2-3613	36	13	3 <sup>5</sup> / <sub>16</sub>	21	<b>124.00</b>
TBDA2-3616	36	16	3 <sup>5</sup> / <sub>16</sub>	25	<b>153.00</b>

Slotted on 1" centers for dividers, with 5" backstop. Five adjustable dividers provided per shelf. Kickplates for adjustable base shelves are furnished with black powder coat finish. If 30" shelves are desired, change the number "36" to "30" (e.g. TBDF2-3010 or TBDA2-3010). Call factory for prices and weights on 30" shelves.

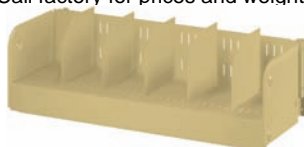

### CLOSED BASE SHELVES (DOUBLE FACE) WITH INTEGRAL BACK & DIVIDERS

CAT. NO.	W	D	H	WT.	PRICE
<b>FOR FIXED BASE SHELVES</b>					
TBDF2-3620	36	20	3 <sup>5</sup> / <sub>16</sub>	34	<b>181.00</b>
TBDF2-3624	36	24	3 <sup>5</sup> / <sub>16</sub>	37	<b>197.00</b>
TBDF2-3626	36	26	3 <sup>5</sup> / <sub>16</sub>	39	<b>211.00</b>
TBDF2-3632	36	32	3 <sup>5</sup> / <sub>16</sub>	47	<b>255.00</b>
<b>FOR ADJUSTABLE BASE SHELVES</b>					
TBDA2-3620	36	20	3 <sup>5</sup> / <sub>16</sub>	35	<b>190.00</b>
TBDA2-3624	36	24	3 <sup>5</sup> / <sub>16</sub>	38	<b>202.00</b>
TBDA2-3626	36	26	3 <sup>5</sup> / <sub>16</sub>	40	<b>220.00</b>
TBDA2-3632	36	32	3 <sup>5</sup> / <sub>16</sub>	48	<b>282.00</b>

Slotted on 1" centers for dividers, with 5" backstop. Five adjustable dividers provided per shelf. Kickplates for adjustable base shelves are furnished with black powder coat finish. If 30" shelves are desired, change the number "36" to "30" (e.g. TBDF2-3020 or TBDA2-3020). Call factory for prices and weights on 30" shelves.



# INTEGRAL BACK BASE SHELVES, SLOPING BASE SHELVES

**ESTEY**  
DIVISION OF TENNSCO CORP.

## INTEGRAL BACK BASE SHELVES (SINGLE FACE)

CAT. NO.	W	D	H	WT.	PRICE
WIBBS2-3008A	30	8	3 <sup>5</sup> / <sub>16</sub>	10.2	96.00
WIBBS2-3009A	30	9	3 <sup>5</sup> / <sub>16</sub>	10.8	99.00
WIBBS2-3010A	30	10	3 <sup>5</sup> / <sub>16</sub>	12.0	97.00
WIBBS2-3012A	30	12	3 <sup>5</sup> / <sub>16</sub>	13.2	104.00
WIBBS2-3013A	30	13	3 <sup>5</sup> / <sub>16</sub>	14.2	127.00
WIBBS2-3016A	30	16	3 <sup>5</sup> / <sub>16</sub>	22.0	130.00
WIBBS2-3608A	36	8	3 <sup>5</sup> / <sub>16</sub>	11.2	96.00
WIBBS2-3609A	36	9	3 <sup>5</sup> / <sub>16</sub>	11.9	99.00
WIBBS2-3610A	36	10	3 <sup>5</sup> / <sub>16</sub>	13.2	97.00
WIBBS2-3612A	36	12	3 <sup>5</sup> / <sub>16</sub>	14.6	104.00
WIBBS2-3613A	36	13	3 <sup>5</sup> / <sub>16</sub>	15.5	119.00
WIBBS2-3616A	36	16	3 <sup>5</sup> / <sub>16</sub>	23.0	130.00
DIVIDER ONLY					
EWD-1	3 <sup>3</sup> / <sub>16</sub>	8	6 <sup>1</sup> / <sub>2</sub>	0.4	8.60
EWD-2	3 <sup>3</sup> / <sub>16</sub>	12	6 <sup>1</sup> / <sub>2</sub>	0.6	9.70

Includes one wire divider per opening. If adjustable base is required, add an "A" after the "WIBBS" when ordering (e.g. WIBBSA2-xxxxA). Call factory for adjustable base pricing and weights.

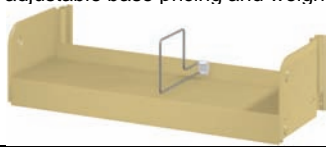

## INTEGRAL BACK BASE SHELVES (DOUBLE FACE)

CAT. NO.	W	D	H	WT.	PRICE
WIBBS2-3018A	30	18	3 <sup>5</sup> / <sub>16</sub>	20	167.00
WIBBS2-3020A	30	20	3 <sup>5</sup> / <sub>16</sub>	21	169.00
WIBBS2-3024A	30	24	3 <sup>5</sup> / <sub>16</sub>	25	188.00
WIBBS2-3026A	30	26	3 <sup>5</sup> / <sub>16</sub>	26	214.00
WIBBS2-3032A	30	32	3 <sup>5</sup> / <sub>16</sub>	31	232.00
WIBBS2-3618A	36	18	3 <sup>5</sup> / <sub>16</sub>	22	167.00
WIBBS2-3620A	36	20	3 <sup>5</sup> / <sub>16</sub>	24	169.00
WIBBS2-3624A	36	24	3 <sup>5</sup> / <sub>16</sub>	27	188.00
WIBBS2-3626A	36	26	3 <sup>5</sup> / <sub>16</sub>	29	214.00
WIBBS2-3632A	36	32	3 <sup>5</sup> / <sub>16</sub>	34	232.00
DIVIDER ONLY					
EWD-1	3 <sup>3</sup> / <sub>16</sub>	8	6 <sup>1</sup> / <sub>2</sub>	0.4	8.60
EWD-2	3 <sup>3</sup> / <sub>16</sub>	12	6 <sup>1</sup> / <sub>2</sub>	0.6	9.70

Includes one wire divider per opening. If adjustable base is required, add an "A" after the "WIBBS" when ordering (e.g. WIBBSA2-xxxxA). Call factory for adjustable base pricing and weights.

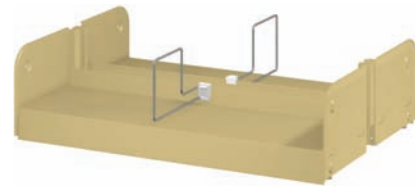

## SLOPING BASE SHELVES (SINGLE FACE)

CAT. NO.	W	D	H	WT.	PRICE
WSB2-3009A	30	9	3 <sup>7</sup> / <sub>8</sub>	11.6	89.00
WSB2-3010A	30	10	3 <sup>7</sup> / <sub>8</sub>	14.3	83.00
WSB2-3012A	30	12	3 <sup>7</sup> / <sub>8</sub>	15.6	88.00
WSB2-3609A	36	9	3 <sup>7</sup> / <sub>8</sub>	11.1	89.00
WSB2-3610A	36	10	3 <sup>7</sup> / <sub>8</sub>	14.9	83.00
WSB2-3612A	36	12	3 <sup>7</sup> / <sub>8</sub>	15.6	88.00
VIDEO SLOPING BASE SHELVES (6 Dividers Included)					
VC2-3012A	30	12	3 <sup>7</sup> / <sub>8</sub>	19.1	119.00
VC2-3612A	36	12	3 <sup>7</sup> / <sub>8</sub>	20.0	119.00

Sloping Base Shelves and Video Sloping Base Shelves are sloped at 9°, aiding visually those items displayed on the bottom shelf. Video Sloping Base Shelves are slotted on 1" centers for dividers, with 5" integral backstop; six adjustable dividers are provided. Adjustable base also available; call factory for details.



## SLOPING BASE SHELVES (DOUBLE FACE)

CAT. NO.	W	D	H	WT.	PRICE
WSB2-3018A	30	18	3 <sup>7</sup> / <sub>8</sub>	24	138.00
WSB2-3020A	30	20	3 <sup>7</sup> / <sub>8</sub>	24	138.00
WSB2-3024A	30	24	3 <sup>7</sup> / <sub>8</sub>	31	152.00
WSB2-3618A	36	18	3 <sup>7</sup> / <sub>8</sub>	23	138.00
WSB2-3620A	36	20	3 <sup>7</sup> / <sub>8</sub>	26	138.00
WSB2-3624A	36	24	3 <sup>7</sup> / <sub>8</sub>	31	152.00
VIDEO SLOPING BASE SHELVES (12 Dividers Included)					
VC2-3012DA	30	24	3 <sup>7</sup> / <sub>8</sub>	38	216.00
VC2-3612DA	36	24	3 <sup>7</sup> / <sub>8</sub>	36	216.00

Sloping Base Shelves and Video Sloping Base Shelves are sloped at 9°, aiding visually those items displayed on the bottom shelf. Video Sloping Base Shelves are slotted on 1" centers for dividers, with 5" integral backstop; twelve adjustable dividers are provided. Adjustable base also available; call factory for details.





**ADJUSTABLE SHELVES**

CAT. NO.	W	D	H	WT.	PRICE
BL3008A	30	8	13/16	5.9	29.00
BL3009A	30	9	13/16	6.7	33.00
BL3010A	30	10	13/16	7.6	36.00
BL3011A	30	11	13/16	8.4	38.00
BL3012A	30	12	13/16	8.8	41.00
BL3013A	30	13	13/16	9.3	47.00
BL3014A	30	14	13/16	10.3	49.00
BL3016A	30	16	13/16	12.3	55.00
BL3608A	36	8	13/16	6.7	29.00
BL3609A	36	9	13/16	7.6	33.00
BL3610A	36	10	13/16	8.6	36.00
BL3611A	36	11	13/16	9.5	38.00
BL3612A	36	12	13/16	10.0	41.00
BL3613A	36	13	13/16	10.5	47.00
BL3614A	36	14	13/16	11.6	49.00
BL3616A	36	16	13/16	13.8	55.00

Includes shelf brackets. Can be furnished in additional widths or depths; contact factory for pricing.



**SHELF BRACKETS**

CAT. NO.	W	D	H	WT.	PRICE
ASBRK08L*	1/4	8	7 1/2	0.9	4.60
ASBRK09L*	1/4	9	7 1/2	1.1	5.10
ASBRK10L*	1/4	10	7 1/2	1.3	5.60
ASBRK11L*	1/4	11	7 1/2	1.5	6.10
ASBRK12L*	1/4	12	7 1/2	1.5	6.50
ASBRK13L*	1/4	13	7 1/2	1.5	7.40
ASBRK14L*	1/4	14	7 1/2	1.8	8.20
ASBRK16L*	1/4	16	7 1/2	2.4	9.00

Attaches shelves to unit uprights. \*NOTE: Listed catalog numbers are for left bracket only; for right bracket, change the suffix "L" to "R".



LEFT BRACKET



RIGHT BRACKET

**ADJUSTABLE DIVIDER SHELVES**

CAT. NO.	W	D	H	WT.	PRICE
BDA3010A	30	10	13/16	12.4	71.00
BDA3011A	30	11	13/16	14.2	75.00
BDA3012A	30	12	13/16	14.5	77.00
BDA3013A	30	13	13/16	14.0	83.00
BDA3016A	30	16	13/16	20.0	111.00
BDA3610A	36	10	13/16	13.7	71.00
BDA3611A	36	11	13/16	15.7	75.00
BDA3612A	36	12	13/16	15.0	77.00
BDA3613A	36	13	13/16	15.5	83.00
BDA3616A	36	16	13/16	20.0	111.00

Slotted on 1" centers to accommodate dividers. Includes 5" back, brackets, and 5 dividers per shelf.

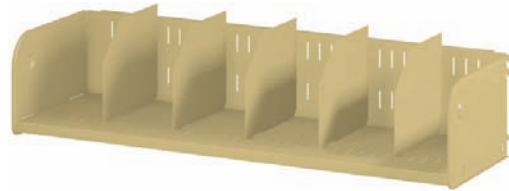

**DIVIDERS**

CAT. NO.	USE WITH	D	H	WT.	PRICE
DIV07	7" & 8" Shelves	7	6	0.4	2.10
DIV09	10" through 13"	9	7 1/2	0.7	3.30
DIV12	14" through 16"	12	7 1/2	1.0	4.70
SPD12	14" through 16"	9	12	1.6	9.60

DIV07



DIV09



DIV12



SPD12



**SHIMS**

CAT. NO.	W	D	H	WT.	PRICE
SHIM	2	2 1/2	1/16	0.1	.98

Used to aid in the leveling of fixed base units. Zinc finish.



# BOOK CARTS, BOOK TRUCKS INTRODUCTION TO ACCESSORIES

**ESTEY**  
DIVISION OF TENNSCO CORP.

## BOOK CARTS



42"H cart with 2 single entry shelves



65"H cart with 4 double entry shelves

CAT. NO.	NO. & TYPE OF SHELVES	W	D	H	WT.	PRICE
<b>42" HEIGHT, 18" DEEP CARTS</b>						
BC361842D2	2 Double Entry	36	18	42	70	<b>525.00</b>
BC361842D1	1 Double Entry, 1 Single Entry	36	18	42	65	<b>476.00</b>
BC361842D0	2 Single Entry	36	18	42	68	<b>441.00</b>
<b>42" HEIGHT, 24" DEEP CART</b>						
BC362442D2	2 Double Entry	36	24	42	90	<b>614.00</b>
<b>65" HEIGHT, 18" DEEP CARTS</b>						
BC361857D4	4 Double Entry	36	18	65	125	<b>877.00</b>
BC361857D3	3 Double Entry, 1 Single Entry	36	18	65	120	<b>837.00</b>
BC361857D2	2 Double Entry, 2 Single Entry	36	18	65	114	<b>798.00</b>
BC361857D1	1 Double Entry, 3 Single Entry	36	18	65	110	<b>758.00</b>
BC361857D0	4 Single Entry	36	18	65	104	<b>758.00</b>
<b>65" HEIGHT, 24" DEEP CART</b>						
BC362457D4	4 Double Entry	36	24	65	140	<b>948.00</b>

Dividers for these carts are also available. Please see dividers on page 12; order divider size DIV07.

## BOOK TRUCKS



ESBT-4320A

ESBT-4328A

CAT. NO.	NO. & TYPE OF SHELVES	W	D	H	WT.	PRICE
ESBT-4320A	With three sloping shelves	20	13	42	44	<b>520.00</b>
ESBT-4328A	With three flat shelves	31	17	42	60	<b>536.00</b>

ESBT-4320A is a single entry book truck with three sloping shelves; ESBT-4328A is a double entry book truck with three flat shelves.

# ACCESSORIES

The next section is devoted to a variety of accessories for your Estey shelving. **Estey Accessories** fit all weld frame units. Most accessory shelving is installable by simply inserting the bracket hooks into the upright slots as shown at right.

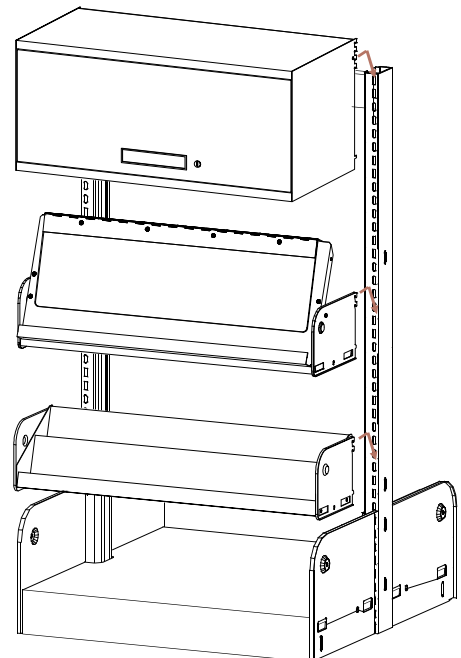

**PERIODICAL DISPLAY SHELVES**

CAT. NO.	W	D	H	WT.	PRICE
PDS3012A	30	12	14	17.0	<b>89.00</b>
PDS3612A	36	12	14	17.8	<b>89.00</b>
PDS3012ACLH*	30	12	14	14.7	<b>114.00</b>
PDS3612ACLH*	36	12	14	17.8	<b>114.00</b>
<b>WITH PLEXIGLASS COVER</b>					
PDSCA30	30	12	14	22.0	<b>179.00</b>
PDSCA	36	12	14	23.0	<b>179.00</b>

Sloped for display. 14" high periodical surface.  
\* Includes continuous label holder.



PERIODICAL DISPLAY SHELF

PERIODICAL DISPLAY SHELF  
WITH PLEXIGLASS COVER

**SLOPED DISPLAY SHELVES**

CAT. NO.	W	D	H	WT.	PRICE
SDS3012A	30	12	12	7.1	<b>61.00</b>
SDS3612A	36	12	12	9.4	<b>61.00</b>
SDS3012ACLH*	30	12	12	12.9	<b>94.00</b>
SDS3612ACLH*	36	12	12	9.0	<b>94.00</b>
<b>WITH PLEXIGLASS COVER</b>					
SDSCA30	30	12	12	11.5	<b>160.00</b>
SDSCA	36	12	12	11.5	<b>160.00</b>

Sloped for display. Fixed or pivot optional. 12" periodical surface.  
\* Includes continuous label holder.



SLOPED DISPLAY SHELF

SLOPED DISPLAY SHELF  
WITH PLEXIGLASS COVER

**INTEGRAL BACK SHELVES**

CAT. NO.	W	D	H	WT.	PRICE
BLIB3608A	36	8	13/16	7.4	<b>43.00</b>
BLIB3609A	36	9	13/16	8.3	<b>46.00</b>
BLIB3610A	36	10	13/16	9.1	<b>48.00</b>
BLIB3611A	36	11	13/16	10.1	<b>52.00</b>
BLIB3612A	36	12	13/16	10.8	<b>55.00</b>
BLIB3613A	36	13	13/16	11.1	<b>61.00</b>
BLIB3616A	36	16	13/16	14.3	<b>70.00</b>

Built-in 2" backstop keeps items organized. Includes brackets and one wire divider per shelf. For 30" shelf, change "BLIB36" to "BLIB30" (e.g. BLIB3016A).

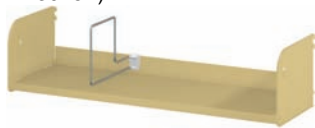

**SLOPED INTEGRAL BACK SHELVES**

CAT. NO.	W	D	H	WT.	PRICE
SIBS3608A	36	8	13/16	7.4	<b>41.00</b>
SIBS3609A	36	9	13/16	8.1	<b>39.00</b>
SIBS3610A	36	10	13/16	8.7	<b>42.00</b>
SIBS3611A	36	11	13/16	9.6	<b>42.00</b>
SIBS3612A	36	12	13/16	10.4	<b>48.00</b>
SIBS3613A	36	13	13/16	10.9	<b>48.00</b>
SIBS3616A	36	16	13/16	14.8	<b>57.00</b>

Built-in 2" backstop keeps items from falling off sloped shelf. For 30" shelf, change "SIBS36" to "SIBS30" (e.g. SIBS3016A).

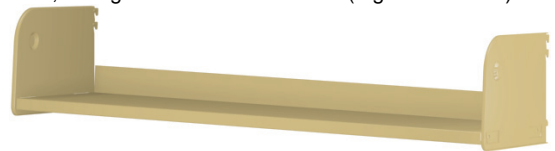

**MULTIPURPOSE DISPLAY SHELVES**

CAT. NO.	TYPE	W	D	H	WT.	PRICE
MP3610A	No Dividers	36	10	8	10.2	<b>57.00</b>
MPD3610A	With Dividers	36	10	8	12.4	<b>69.00</b>

Two-positional shelf allows you to have either a sloping display shelf or (reversed) an integral back shelf. Ideal for displaying video tapes, audio cassettes, easy books, art books, etc. Divider shelves come with 6 dividers.



AS SLOPING DISPLAY SHELF

AS INTEGRAL BACK SHELF

**MULTIPURPOSE BASE SHELVES**

CAT. NO.	TYPE	W	D	H	WT.	PRICE
<b>SINGLE ENTRY</b>						
MPB2-3610A	No Dividers	36	10	8	15.0	<b>94.00</b>
MPDB2-3610A	With Dividers	36	20	8	17.2	<b>106.00</b>
<b>DOUBLE ENTRY</b>						
MPB2-3620A	No Dividers	36	10	8	37.0	<b>164.00</b>
MPDB2-3620A	With Dividers	36	20	8	42.0	<b>189.00</b>

Two-positional shelf can be used as either a sloping display shelf or (reversed) an integral back shelf. Divider shelves come with 6 dividers.



SINGLE ENTRY

DOUBLE ENTRY

# ACCESSORIES: SPECIALTY SHELVES

**ESTEY**  
DIVISION OF TENNSCO CORP.

## STORAGE SHELVES

CAT. NO.	W	D	H	WT.	PRICE
IN3610A	36	10	13/16	7.0	<b>34.00</b>
IN3612A	36	12	13/16	8.2	<b>40.00</b>
IN3613A	36	13	13/16	8.7	<b>46.00</b>
IN3614A	36	14	13/16	9.6	<b>50.00</b>
IN3616A	36	16	13/16	10.6	<b>54.00</b>
IN3618A	36	18	13/16	11.8	<b>71.00</b>
IN3619A	36	19	13/16	12.5	<b>79.00</b>

Used with sloped display shelves (at left on page 16), or any place where a flat shelf is desired. For 30" shelf, change "IN36" to "IN30" (e.g. IN3010A).



## SLIDING REFERENCE SHELVES

CAT. NO.	W	D	H	WT.	PRICE
SRS3008A	30	8	3	7.4	<b>162.00</b>
SRS3009A	30	9	3	6.0	<b>139.00</b>
SRS3010A	30	10	3	10.6	<b>159.00</b>
SRS3012A	30	12	3	12.6	<b>147.00</b>
SRS3608A	36	8	3	7.4	<b>162.00</b>
SRS3609A	36	9	3	6.0	<b>139.00</b>
SRS3610A	36	10	3	11.5	<b>159.00</b>
SRS3612A	36	12	3	13.6	<b>147.00</b>

Sturdy full extension slides attach to underside of adjustable shelf. Use two reference shelves for double face units.



## FACE-OUT DISPLAY SHELF

CAT. NO.	W	D	H	WT.	PRICE
FODSA	36	2 3/4	5 9/16	6.2	<b>35.00</b>

Used to display compact discs and DVDs.



## DOUBLE TIER VIDEO CASSETTE & AUDIO CASSETTE SHELVES

CAT. NO.	W	D	H	WT.	PRICE
<b>VIDEO CASSETTE SHELF</b>					
VCDT3014	30	14	12	20.0	<b>155.00</b>
VCDT3614	36	14	12	20.0	<b>155.00</b>
<b>AUDIO CASSETTE/MICROFILM SHELF</b>					
SPMF30A	30	10	7 1/2	12.3	<b>193.00</b>
SPMF36A	36	10	7 1/2	12.3	<b>193.00</b>

**Double Tier Video Cassette Shelf** (below, left) is used with compact discs, video cassettes, or paperbacks. Sloped; 36" wide shelf holds 60 videotapes or 160 compact discs. **Audio Cassette Shelf** (below, right) stores microfilm or audio cassettes. Capacity: 100 cassettes (36" wide shelf).



## VIDEO CASSETTE/ PAPERBACK BOOK SHELF

CAT. NO.	W	D	H	WT.	PRICE
VCS3007A	30	6	7 1/2	11.1	<b>67.00</b>
VCS3607A	36	6	7 1/2	10.4	<b>67.00</b>
VCS3008A	30	7	7 1/2	10.2	<b>66.00</b>
VCS3608A	36	7	7 1/2	11.1	<b>66.00</b>
DIV07	<b>(DIVIDER ONLY)</b>			0.4	<b>2.10</b>

Slopes to allow convenient viewing of spines on paperbacks and video cassettes. Six adjustable dividers included per shelf.

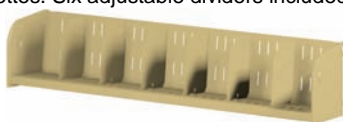

## ZIG-ZAG SHELF

CAT. NO.	W	D	H	WT.	PRICE
ZZ3008A	30	7	5 13/16	10.0	<b>88.00</b>
ZZ3608A	36	7	5 13/16	10.8	<b>88.00</b>
<b>INSERT ONLY</b>					
ZZPD	36	18	5	3.8	<b>54.00</b>

Adjustable shelf with paperback insert. Ideal for displaying audio cassette or paperback books.

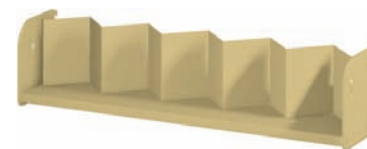

**CABINETS**

CAT. NO.	W	D	H	WT.	PRICE
<b>CABINET ONLY</b>					
FDCB36L	36	17 <sup>5</sup> / <sub>8</sub>	15 <sup>1</sup> / <sub>2</sub>	53	1,051.00
<b>CABINET WITH 1 PULL-OUT FRAME</b>					
CBFD36LFA	36	17 <sup>5</sup> / <sub>8</sub>	15 <sup>1</sup> / <sub>2</sub>	63	1,604.00
<b>CABINET WITH 2 PULL-OUT FRAMES</b>					
CBFD36L2FA	36	17 <sup>5</sup> / <sub>8</sub>	15 <sup>1</sup> / <sub>2</sub>	73	2,156.00
<b>FRAME ONLY</b>					
FRAME36A	36	16	2	10.1	551.00

All welded construction. Ideal for storing valuable items that need to be secured. Includes flipper door and lock with two keys.



Cabinet Only

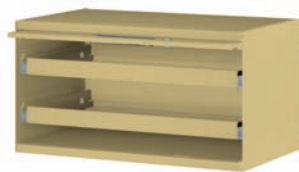

Cabinet With 2 Pull-Out Frames

**MEDIA HANGER RACK**

CAT. NO.	W	D	H	WT.	PRICE
HB30A	30	6 <sup>1</sup> / <sub>2</sub>	4 <sup>1</sup> / <sub>4</sub>	2.1	63.00
HB36A	36	6 <sup>1</sup> / <sub>2</sub>	4 <sup>1</sup> / <sub>4</sub>	2.1	63.00

Consists of brackets with hanger rod for clear-view plastic media bags.



**METAL TRAYS**

CAT. NO.	W	D	H	WT.	PRICE
<b>FOR COMPACT DISCS</b>					
TRCD514A	5 <sup>1</sup> / <sub>16</sub>	14 <sup>3</sup> / <sub>8</sub>	4 <sup>1</sup> / <sub>2</sub>	4.4	318.00
CDD-1 (Divider Only)				0.2	20.00
<b>FOR AUDIOCASSETTES</b>					
TRAC414A	4 <sup>7</sup> / <sub>16</sub>	14 <sup>3</sup> / <sub>8</sub>	3 <sup>1</sup> / <sub>8</sub>	3.3	345.00
ACD-1 (Divider Only)				0.2	31.00
<b>FOR VHS TAPES</b>					
TRVHS714A	7 <sup>5</sup> / <sub>8</sub>	14 <sup>3</sup> / <sub>8</sub>	3 <sup>1</sup> / <sub>8</sub>	5.1	305.00
VHSD-1 (Divider Only)				0.3	23.00
<b>FOR 3x5 CARDS</b>					
TRCRD3X5A	5 <sup>3</sup> / <sub>16</sub>	14 <sup>3</sup> / <sub>8</sub>	3 <sup>1</sup> / <sub>8</sub>	3.9	402.00
CRDD-1 (Divider Only)				0.2	50.00

Handy metal trays store a wide variety of media. Use alone or in conjunction with Estey cabinets.



**METAL BROWSING BOX**

CAT. NO.	W	D	H	WT.	PRICE
BRB3005A	30	14 <sup>1</sup> / <sub>2</sub>	5 <sup>1</sup> / <sub>2</sub>	13.5	193.00
BRB3605A	36	14 <sup>1</sup> / <sub>2</sub>	5 <sup>1</sup> / <sub>2</sub>	15.3	193.00
BRBWD (Divider Only)				0.1	6.60

Ideal for storing all media items. Includes 2 wire dividers.



BROWSING BOX

DIVIDER

**WORK SHELF AND BRACKETS**

CAT. NO.	W	D	H	WT.	PRICE
LC54A	36	24	27 <sup>1</sup> / <sub>2</sub>	30.0	761.00
LCL (Legs Only, Per Pair)				3.0	83.00
LCBRK24L (Left Bracket Only)				3.6	89.00
LCBRK24R (Right Bracket Only)				3.6	89.00

24" deep plastic shelf supported by two steel triangular brackets for work surface within shelving range. Must state desired finish of work shelf.



WORK SHELF AND BRACKETS



LEGS

**PULL-OUT BROWSING BOX**

CAT. NO.	W	D	H	WT.	PRICE
<b>WITH SLIDING DIVIDER</b>					
XBRB43611A	36	11 <sup>1</sup> / <sub>2</sub>	5 <sup>1</sup> / <sub>2</sub>	29	388.00
TXBWD (Divider Only)				0.3	7.60
<b>WITH PLATE-TYPE DIVIDER and 3" FRONT</b>					
XHDBRB3611A	36	11 <sup>1</sup> / <sub>2</sub>	5 <sup>1</sup> / <sub>2</sub>	29	515.00
BRBDIVA (Divider Only)				0.4	3.70

A pull out browsing box mounted on full-extension ball-bearing suspensions. Ideal for storing all media items. XBRB3611A includes 2 wire dividers; XDBRB3611A includes 4 plate-type dividers.



XBRB43611A

XHDBRB3611A

**NOTE:** The original XBRB3611A, with full-height front, is still available for a list price of \$515.00 and a weight of 30 lbs. Contact factory for further details.



# SPECIALTY SHELVES, BRACING, LABELING ACCESSORIES

**ESTEY**  
DIVISION OF TENNSCO CORP.

## NEWSPAPER RACK

CAT. NO.	DESC.	W	D	H	WT.	PRICE
NPR6	6 Holders	36	12	14	9.6	719.00
NPR10	10 Holders	36	12	22	15.2	1,061.00

Displays newspapers. Newspaper sticks included.



## TRANSVERSE OVERHEAD TOP TIE BRACING

CAT. NO.	W	D	H	WT.	PRICE
<b>FOR WELD FRAME</b>					
OTBW9	96	2	7/8	5.7	29.00

Channel construction top tie furnished in 8 foot lengths. Recommended for added stabilization when bases and shelves are of equal depths.

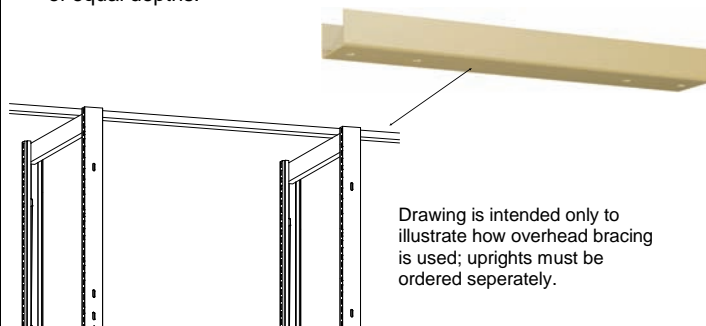

## WALL HUNG COLUMNS

CAT. NO.	W	D	H	WT.	PRICE
PILWCH24	1 1/2	1	24	2.4	33.00
PILWCH30	1 1/2	1	30	2.4	35.00
PILWCH42	1 1/2	1	42	3.1	41.00
PILWCH54	1 1/2	1	54	3.8	45.00
PILWCH60	1 1/2	1	60	3.8	46.00
PILWCH66	1 1/2	1	66	3.8	48.00
PILWCH72	1 1/2	1	72	4.5	49.00
PILWCH78	1 1/2	1	78	4.5	51.00
PILWCH84	1 1/2	1	84	4.8	52.00
PILWCH90	1 1/2	1	90	5.2	54.00

Slotted strip attaches to wall. Designed to accept all components or accessory items. Special heights available. Hardware not included because of various wall construction.



## SHELF LABEL HOLDER

CAT. NO.	W	D	H	WT.	PRICE
SLH	5 1/2	—	3 3/4	0.1	.84

Plastic clip-on holder for 5/8" x 5" card.



## WALL CLIP

CAT. NO.	W	D	H	WT.	PRICE
WCLIP	3	2	1	0.2	.99

Used to attach single face units to the wall for support.



## CARD HOLDERS

CAT. NO.	W	D	H	WT.	PRICE
<b>SINGLE CARD HOLDER</b>					
SCH-B	5 1/4	—	3 1/8	0.1	2.50
<b>DOUBLE CARD HOLDER</b>					
DCH-B	10 1/4	—	3 1/8	0.2	4.20
<b>ALUMINUM HOLDER</b>					
SCH-CA	5 5/8	—	3 1/2	0.1	2.80

For 3" x 5" cards. Used on end panels. Attaches with double-sided tape. Steel holders are finished in black powder coat paint.

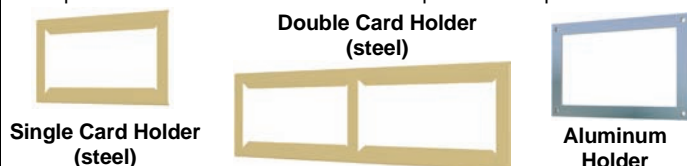

Single Card Holder  
(steel)

Double Card Holder  
(steel)

Aluminum  
Holder

## RANGE FINDER

CAT. NO.	W	D	H	WT.	PRICE
RFP6	—	6 3/4	3 1/8	0.2	4.50

For use on end panels or uprights for identification of range contents. Attaches with double-sided tape. Holds two 3" x 5" cards. Finished in black.



**STEEL BOOK SUPPORTS**

CAT. NO.	W	D	H	WT.	PRICE
<b>WITH CORK BACKING</b>					
BSN6	4 <sup>9</sup> / <sub>16</sub>	5 <sup>1</sup> / <sub>2</sub>	6	0.6	5.40
BSN9	4 <sup>9</sup> / <sub>16</sub>	5 <sup>1</sup> / <sub>2</sub>	9	1.1	6.60
<b>WITH MAGNETIC STRIP</b>					
BSM6	4 <sup>9</sup> / <sub>16</sub>	5 <sup>1</sup> / <sub>2</sub>	6	1.0	5.40
BSM9	4 <sup>9</sup> / <sub>16</sub>	5 <sup>1</sup> / <sub>2</sub>	9	1.1	6.60

Unattached book support used on surface of shelves. Furnished with cork backing or a magnetic strip, as specified above.



**HOOK-ON STEEL BOOK SUPPORT**

CAT. NO.	W	D	H	WT.	PRICE
LOBS6	4 <sup>9</sup> / <sub>16</sub>	1 <sup>3</sup> / <sub>4</sub>	6	0.6	7.30
LOBS9	4 <sup>9</sup> / <sub>16</sub>	1 <sup>3</sup> / <sub>4</sub>	9	1.2	8.30

Hooks onto return flange of adjustable shelves for rigid support.



**SHELF FILLER**

CAT. NO.	W	D	H	WT.	PRICE
SHFIL30	27	2 <sup>5</sup> / <sub>8</sub>	1	2.3	27.00
SHFIL36	33	2 <sup>5</sup> / <sub>8</sub>	1	2.6	27.00

Fills the space between adjustable shelves on double sided units, providing a continuous surface. Attaches with two clips that fasten to underside of shelves.



**WIRE BOOK SUPPORTS**

CAT. NO.	TYPE	W	D	H	WT.	PRICE
WBS6	"V"	3 <sup>3</sup> / <sub>16</sub>	—	6	0.2	2.70
WBS9	"V"	3 <sup>3</sup> / <sub>16</sub>	—	9	0.3	3.40
WBSW7	"W"	3 <sup>3</sup> / <sub>16</sub>	—	7	0.3	3.20
WBSW9	"W"	3 <sup>3</sup> / <sub>16</sub>	—	9	0.4	3.90

Heavy spring wire book support. Rubber tipped to prevent slippage. Attaches to underside of shelf. Easily adjustable.

6-INCH "V" SUPPORT



9-INCH "V" SUPPORT



7-INCH "W" SUPPORT



9-INCH "W" SUPPORT



**NOTE:** Dividers are shown attached to shelves for clarification purposes only; shelves must be ordered separately.

**SLOPED ADJUSTABLE END BRACKET**

CAT. NO.	W	D	H	WT.	PRICE
SASBRK08LJ*	1/4	8	7 <sup>1</sup> / <sub>2</sub>	1.1	8.20
SASBRK09LJ*	1/4	9	7 <sup>1</sup> / <sub>2</sub>	1.2	6.20
SASBRK10LJ*	1/4	10	7 <sup>1</sup> / <sub>2</sub>	1.3	7.10
SASBRK11LJ*	1/4	11	7 <sup>1</sup> / <sub>2</sub>	1.5	9.30
SASBRK12LJ*	1/4	12	7 <sup>1</sup> / <sub>2</sub>	1.6	7.90
SASBRK13LJ*	1/4	13	7 <sup>1</sup> / <sub>2</sub>	1.7	10.30
SASBRK14LJ*	1/4	14	7 <sup>1</sup> / <sub>2</sub>	1.9	10.80

Creates 7 degrees of slope for an adjustable shelf. **\*NOTE:** Listed catalog numbers are for left bracket only; for right bracket, change the suffix "LJ" to "RJ".



LEFT BRACKET



RIGHT BRACKET

# ACCESSORIES: BACKSTOPS, BASE FILLERS, ANCHORS

**ESTEY**  
DIVISION OF TENNSCO CORP.

## BASE FILLER CLOSURES

CAT. NO.	W	D	H	WT.	PRICE
<b>FOR WELD FRAME</b>					
BFC30	30	2 <sup>3</sup> / <sub>4</sub>	1	2.0	8.10
BFC36	36	2 <sup>3</sup> / <sub>4</sub>	1	1.6	8.10

Use to fill space between uprights when an adjustable base is used.



CAT. NO.	W	D	H	WT.	PRICE
<b>FOR MOBILE CARRIAGE</b>					
BCC30	30	2 <sup>1</sup> / <sub>2</sub>	1 <sup>3</sup> / <sub>4</sub>	2.1	25.00
BCC36	36	2 <sup>1</sup> / <sub>2</sub>	1 <sup>3</sup> / <sub>4</sub>	2.5	25.00

Use to fill space between uprights when adjustable shelves are used on bottom of unit.



## OFFSET CENTER BACKSTOP —LARGE PROFILE

CAT. NO.	W	D	H	WT.	PRICE
CBS30	30	3/8	3 <sup>9</sup> / <sub>32</sub>	1.7	21.00
CBS36	36	3/8	3 <sup>9</sup> / <sub>32</sub>	2.1	21.00

Works as a backstop for each side of a double entry unit, eliminating the need for an individual backstop for each side.



## OFFSET CENTER BACKSTOP —SMALL PROFILE

CAT. NO.	W	D	H	WT.	PRICE
CBSS30	30	7/16	2	1.4	9.20
CBSS36	36	7/16	2	1.6	9.20

Works as a backstop for each side of a double entry unit, eliminating the need for an individual backstop for each side.



## ADJUSTABLE BACKSTOP

CAT. NO.	W	D	H	WT.	PRICE
ABS36	36	7/16	2	1.5	12.90

Individual backstop designed to engage in upright slots for adjustability.



## REVERSIBLE BACKSTOP & WIRE DIVIDER

CAT. NO.	W	D	H	WT.	PRICE
<b>BACK STOP</b>					
RBS30	30	7/16	2	1.2	7.20
RBS36	36	7/16	2	1.3	7.20
<b>WIRE DIVIDER</b>					
BSWBS	—	8 <sup>1</sup> / <sub>2</sub>	4	0.2	3.10

One side is a regular backstop. The other side is a sliding support backstop (when used with wire divider sold above).



## FLOOR ANCHOR

CAT. NO.	W	D	H	WT.	PRICE
FLRANCH3	1	3	5/8	0.1	1.90

Used to anchor weld frame units to the floor. For use with weld frame base brackets only. Zinc plated.

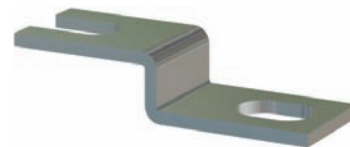

# CANOPY TOPS & ACCESSORIES

## STEEL CANOPY TOPS

CAT. NO.	W	D	H	WT.	PRICE
<b>SINGLE FACE</b>					
CTS2-3008	30	8	—	6.7	<b>44.00</b>
CTS2-3009	30	9	—	6.8	<b>46.00</b>
CTS2-3010	30	10	—	6.9	<b>38.00</b>
CTS2-3012	30	12	—	7.8	<b>42.00</b>
CTS2-3013	30	13	—	8.3	<b>55.00</b>
CTS2-3016	30	16	—	9.8	<b>60.00</b>
CTS2-3608	36	8	—	6.7	<b>44.00</b>
CTS2-3609	36	9	—	7.2	<b>46.00</b>
CTS2-3610	36	10	—	8.0	<b>38.00</b>
CTS2-3612	36	12	—	9.1	<b>42.00</b>
CTS2-3613	36	13	—	9.6	<b>55.00</b>
CTS2-3616	36	16	—	11.5	<b>60.00</b>
<b>DOUBLE FACE</b>					
CTD3016	30	16	—	9.0	<b>67.00</b>
CTD3018	30	18	—	9.7	<b>79.00</b>
CTD3020	30	20	—	11.1	<b>62.00</b>
CTD3024	30	24	—	12.7	<b>72.00</b>
CTD3026	30	26	—	13.6	<b>94.00</b>
CTD3032	30	32	—	16.7	<b>112.00</b>
CTD3616	36	16	—	10.5	<b>67.00</b>
CTD3618	36	18	—	11.3	<b>79.00</b>
CTD3620	36	20	—	12.8	<b>62.00</b>
CTD3624	36	24	—	14.8	<b>72.00</b>
CTD3626	36	26	—	15.7	<b>94.00</b>
CTD3632	36	32	—	19.3	<b>112.00</b>
<b>BRACKETS ONLY *</b>					
CTB08S (1 pair)	—	8	—	1.0	<b>13.30</b>
CTB09S (1 pair)	—	9	—	1.0	<b>13.30</b>
CTB10S (1 pair)	—	10	—	1.3	<b>7.50</b>
CTB12S (1 pair)	—	12	—	1.4	<b>8.30</b>
CTB13S (1 pair)	—	13	—	1.4	<b>14.90</b>
CTB16S (1 pair)	—	16	—	1.8	<b>16.50</b>

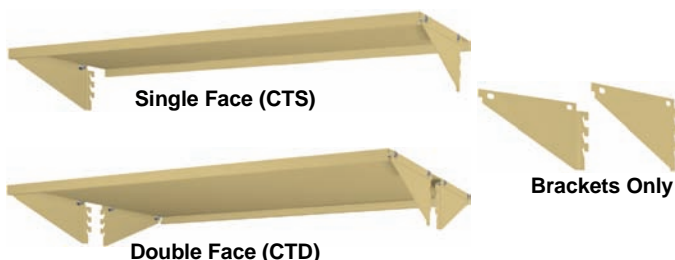

Keeps dust off your valuable materials. Includes attaching brackets.  
\* Attaching bracket is also used to secure steel end panels (see page 24). Each pair consists of one left and one right bracket.

## CANOPY BRACKETS FOR WOOD TOPS

CAT. NO.	W	D	H	WT.	PRICE
CTIB08S (1 pair)	8	—	—	1.0	<b>9.10</b>
CTIB09S (1 pair)	9	—	—	1.0	<b>11.50</b>
CTIB10S (1 pair)	10	—	—	1.2	<b>8.90</b>
CTIB12S (1 pair)	12	—	—	1.4	<b>11.50</b>
CTIB13S (1 pair)	13	—	—	1.4	<b>13.50</b>
CTIB16S (1 pair)	16	—	—	1.8	<b>16.50</b>
CTIB18S (1 pair)	18	—	—	2.0	<b>22.00</b>

Used when wood or hard plastic canopy tops are used. For single face units, use 1 pair. For double face units, use 2 pairs. Each pair consists of one left and one right bracket and hardware. Wood top not

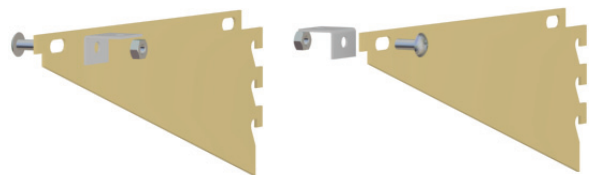

## CANOPY SIGNAGE

CAT. NO.	W	D	H	WT.	PRICE
CPSGN36	35 <sup>1</sup> / <sub>4</sub>	—	1 <sup>3</sup> / <sub>4</sub>	1.5	<b>111.00</b>

Easily identify special items or sections with this customizable label holder. Three attachment clips provided.



## LIGHTING

CAT. NO.	W	D	H	WT.	PRICE
ESTLIGHT36	36	14	3 <sup>5</sup> / <sub>8</sub>	24.0	<b>603.00</b>

Place anywhere more light is needed for display or referencing. Includes: two F25T8 cool white bulbs and acrylic lens in front for signage. Available in all standard colors.

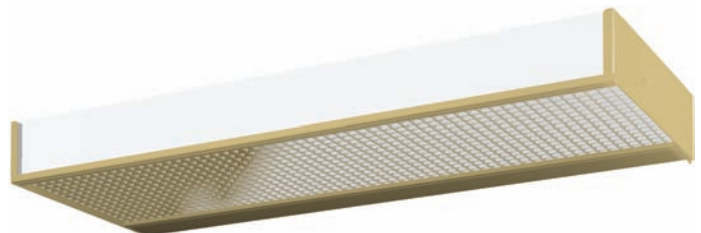

# GUSSETTS AND FILLERS

**ESTEY**  
DIVISION OF TENNSCO CORP.

## FIXED BASE/ADJUSTABLE BASE REINFORCING GUSSETS

CAT. NO.	W	D	H	WT.	PRICE
<b>SINGLE FACE</b>					
GS2-08AL (left)	1/16	8	39 <sup>7</sup> / <sub>8</sub>	5.0	<b>48.00</b>
GS2-08AR (right)	1/16	8	39 <sup>7</sup> / <sub>8</sub>	5.0	<b>48.00</b>
GS2-09AL (left)	1/16	9	39 <sup>7</sup> / <sub>8</sub>	5.9	<b>52.00</b>
GS2-09AR (right)	1/16	9	39 <sup>7</sup> / <sub>8</sub>	5.9	<b>52.00</b>
GS2-10AL (left)	1/16	10	39 <sup>7</sup> / <sub>8</sub>	6.8	<b>55.00</b>
GS2-10AR (right)	1/16	10	39 <sup>7</sup> / <sub>8</sub>	6.8	<b>55.00</b>
GS2-12AL (left)	1/16	12	39 <sup>7</sup> / <sub>8</sub>	7.7	<b>59.00</b>
GS2-12AR (right)	1/16	12	39 <sup>7</sup> / <sub>8</sub>	7.7	<b>59.00</b>
GS2-13AL (left)	1/16	13	39 <sup>7</sup> / <sub>8</sub>	8.5	<b>62.00</b>
GS2-13AR (right)	1/16	13	39 <sup>7</sup> / <sub>8</sub>	8.5	<b>62.00</b>
GS2-16AL (left)	1/16	16	39 <sup>7</sup> / <sub>8</sub>	7.8	<b>71.00</b>
GS2-16AR (right)	1/16	16	39 <sup>7</sup> / <sub>8</sub>	7.8	<b>71.00</b>
<b>DOUBLE FACE</b>					
GD2-081A	1/16	16	39 <sup>7</sup> / <sub>8</sub>	7.6	<b>59.00</b>
GD2-091A	1/16	18	39 <sup>7</sup> / <sub>8</sub>	8.6	<b>63.00</b>
GD2-101A	1/16	20	39 <sup>7</sup> / <sub>8</sub>	9.6	<b>70.00</b>
GD2-121A	1/16	24	39 <sup>7</sup> / <sub>8</sub>	11.3	<b>81.00</b>
GD2-131A	1/16	26	39 <sup>7</sup> / <sub>8</sub>	11.9	<b>87.00</b>
GD2-161A	1/16	32	39 <sup>7</sup> / <sub>8</sub>	11.9	<b>109.00</b>

Used when *fixed base* shelving units are to be mounted on mobile carriage bases or when additional stabilization is required. Also available for *adjustable base* shelving units; to order, add "J" to end of catalog number and call factory for pricing and weights.

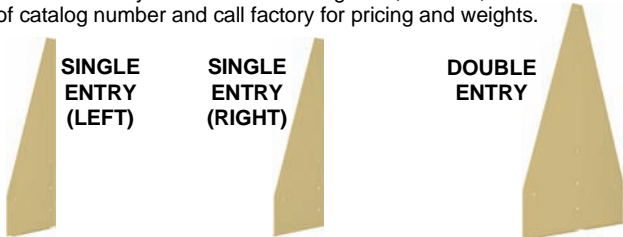

## ADJUSTABLE SHELF REINFORCING GUSSETS

CAT. NO.	W	D	H	WT.	PRICE
<b>SINGLE FACE</b>					
GS2-08CAL (left)	1/16	8	39 <sup>7</sup> / <sub>8</sub>	5.5	<b>48.00</b>
GS2-08CAR (right)	1/16	8	39 <sup>7</sup> / <sub>8</sub>	5.5	<b>48.00</b>
GS2-09CAL (left)	1/16	9	39 <sup>7</sup> / <sub>8</sub>	6.1	<b>51.00</b>
GS2-09CAR (right)	1/16	9	39 <sup>7</sup> / <sub>8</sub>	6.1	<b>51.00</b>
GS2-10CAL (left)	1/16	10	39 <sup>7</sup> / <sub>8</sub>	6.6	<b>54.00</b>
GS2-10CAR (right)	1/16	10	39 <sup>7</sup> / <sub>8</sub>	6.6	<b>54.00</b>
GS2-12CAL (left)	1/16	12	39 <sup>7</sup> / <sub>8</sub>	7.5	<b>59.00</b>
GS2-12CAR (right)	1/16	12	39 <sup>7</sup> / <sub>8</sub>	7.5	<b>59.00</b>
GS2-13CAL (left)	1/16	13	39 <sup>7</sup> / <sub>8</sub>	8.4	<b>62.00</b>
GS2-13CAR (right)	1/16	13	39 <sup>7</sup> / <sub>8</sub>	8.4	<b>62.00</b>
GS2-16CAL (left)	1/16	16	39 <sup>7</sup> / <sub>8</sub>	10.1	<b>71.00</b>
GS2-16CAR (right)	1/16	16	39 <sup>7</sup> / <sub>8</sub>	10.1	<b>71.00</b>
<b>DOUBLE FACE</b>					
GD2-08CA	1/16	16	39 <sup>7</sup> / <sub>8</sub>	6.7	<b>59.00</b>
GD2-09CA	1/16	18	39 <sup>7</sup> / <sub>8</sub>	7.4	<b>63.00</b>
GD2-10CA	1/16	20	39 <sup>7</sup> / <sub>8</sub>	8.3	<b>70.00</b>
GD2-12CA	1/16	24	39 <sup>7</sup> / <sub>8</sub>	8.7	<b>82.00</b>
GD2-13CA	1/16	26	39 <sup>7</sup> / <sub>8</sub>	10.4	<b>89.00</b>
GD2-16CA	1/16	32	39 <sup>7</sup> / <sub>8</sub>	12.6	<b>104.00</b>

Used when *adjustable shelves* (in lieu of a base shelf and base bracket) are used as a base and are to be mounted on mobile carriage tracks only.



## CORNER FILLERS

CAT. NO.	HEIGHTS	DEPTHS	WT.	PRICE
SCF2-hhddA	42" to 93"	8" to 32"		<b>Call Factory</b>

Used to make a corner for units placed at right angles to each other. Available in all heights and depths. Specify height and depth (*hhdd*) when ordering. Over 93" high contact factory.

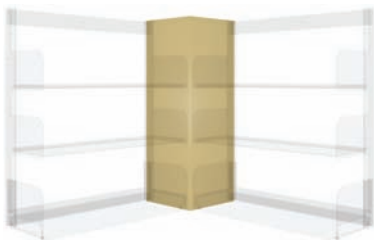

## INTERMEDIATE WALL FILLERS

CAT. NO.	HEIGHTS	DEPTHS	WT.	PRICE
DCF2-hhddA	42" to 93"	8" to 32"		<b>Call Factory</b>

Used to fill a void where two single faced units are joined at a right angle with a double faced unit. Available for all base shelf depths and frame heights. Specify height and depth (*hhdd*) when ordering. Over 93" high contact factory.





**END PANELS—  
SINGLE FACE**



CAT. NO.	BASE DEPTH	HEIGHT	WT.	PRICE
WSP2-4208A	8	42	13.5	<b>109.00</b>
WSP2-4209A	9	42	12.5	<b>111.00</b>
WSP2-4210A	10	42	13.1	<b>120.00</b>
WSP2-4212A	12	42	14.5	<b>125.00</b>
WSP2-4213A	13	42	14.9	<b>127.00</b>
WSP2-4216A	16	42	16.7	<b>135.00</b>
WSP2-6608A	8	66	18.5	<b>139.00</b>
WSP2-6609A	9	66	19.5	<b>150.00</b>
WSP2-6610A	10	66	21.0	<b>151.00</b>
WSP2-6612A	12	66	25.0	<b>155.00</b>
WSP2-6613A	13	66	23.0	<b>159.00</b>
WSP2-6616A	16	66	26.0	<b>170.00</b>
WSP2-7808A	8	78	22.0	<b>152.00</b>
WSP2-7809A	9	78	23.0	<b>157.00</b>
WSP2-7810A	10	78	24.0	<b>165.00</b>
WSP2-7812A	12	78	27.0	<b>173.00</b>
WSP2-7813A	13	78	27.0	<b>178.00</b>
WSP2-7816A	16	78	31.0	<b>192.00</b>
WSP2-8408A	8	84	24.0	<b>159.00</b>
WSP2-8409A	9	84	25.0	<b>164.00</b>
WSP2-8410A	10	84	26.0	<b>172.00</b>
WSP2-8412A	12	84	26.0	<b>180.00</b>
WSP2-8413A	13	84	30.0	<b>185.00</b>
WSP2-8416A	16	84	33.0	<b>192.00</b>
WSP2-9008A	8	90	25.0	<b>168.00</b>
WSP2-9009A	9	90	27.0	<b>172.00</b>
WSP2-9010A	10	90	27.0	<b>180.00</b>
WSP2-9012A	12	90	31.0	<b>190.00</b>
WSP2-9013A	13	90	32.0	<b>195.00</b>
WSP2-9016A	16	90	36.0	<b>200.00</b>
WSP2-9308A	8	93	26.0	<b>198.00</b>
WSP2-9309A	9	93	27.0	<b>204.00</b>
WSP2-9310A	10	93	29.0	<b>210.00</b>
WSP2-9312A	12	93	31.0	<b>221.00</b>
WSP2-9313A	13	93	33.0	<b>227.00</b>
WSP2-9316A	16	93	37.0	<b>243.00</b>

Optional attaching brackets available for added stability; see page 22.

**END PANELS—  
DOUBLE FACE**



CAT. NO.	BASE DEPTH	HEIGHT	WT.	PRICE
WDP2-4216A	16	42	21	<b>183.00</b>
WDP2-4218A	18	42	22	<b>188.00</b>
WDP2-4220A	20	42	24	<b>194.00</b>
WDP2-4224A	24	42	24	<b>198.00</b>
WDP2-4226A	26	42	28	<b>211.00</b>
WDP2-4232A	32	42	23	<b>227.00</b>
WDP2-6616A	16	66	30	<b>233.00</b>
WDP2-6618A	18	66	24	<b>241.00</b>
WDP2-6620A	20	66	34	<b>249.00</b>
WDP2-6624A	24	66	38	<b>261.00</b>
WDP2-6626A	26	66	40	<b>274.00</b>
WDP2-6632A	32	66	46	<b>298.00</b>
WDP2-7816A	16	78	35	<b>255.00</b>
WDP2-7818A	18	78	37	<b>264.00</b>
WDP2-7820A	20	78	39	<b>274.00</b>
WDP2-7824A	24	78	45	<b>280.00</b>
WDP2-7826A	26	78	46	<b>303.00</b>
WDP2-7832A	32	78	53	<b>330.00</b>
WDP2-8416A	16	84	37	<b>269.00</b>
WDP2-8418A	18	84	39	<b>279.00</b>
WDP2-8420A	20	84	33	<b>289.00</b>
WDP2-8424A	24	84	37	<b>296.00</b>
WDP2-8426A	26	84	49	<b>320.00</b>
WDP2-8432A	32	84	57	<b>350.00</b>
WDP2-9016A	16	90	41	<b>278.00</b>
WDP2-9018A	18	90	42	<b>289.00</b>
WDP2-9020A	20	90	46	<b>291.00</b>
WDP2-9024A	24	90	52	<b>309.00</b>
WDP2-9026A	26	90	52	<b>333.00</b>
WDP2-9032A	32	90	60	<b>364.00</b>
WDP2-9316A	16	93	40	<b>281.00</b>
WDP2-9318A	18	93	43	<b>291.00</b>
WDP2-9320A	20	93	46	<b>302.00</b>
WDP2-9324A	24	93	54	<b>324.00</b>
WDP2-9326A	26	93	54	<b>334.00</b>
WDP2-9332A	32	93	62	<b>365.00</b>

Optional attaching brackets available for added stability; see page 22.

**STEEL BACKS**



24" wide backs are also available. Please contact factory for pricing and weights.

CAT. NO.	W	D	H	WT.	PRICE
WNB3042A	30	1	42	18	<b>147.00</b>
WNB3066A	30	1	66	30	<b>224.00</b>
WNB3078A	30	1	78	36	<b>255.00</b>
WNB3084A	30	1	84	39	<b>270.00</b>
WNB3090A	30	1	90	42	<b>285.00</b>
WNB3642A	36	1	42	21	<b>147.00</b>
WNB3666A	36	1	66	35	<b>224.00</b>
WNB3678A	36	1	78	42	<b>255.00</b>
WNB3684A	36	1	84	46	<b>270.00</b>
WNB3690A	36	1	90	49	<b>285.00</b>